

DAS Boot Camp **- Next Generation Wireless Networks**

Mark Niehus, RCDD – Connectivity Wireless Solutions

Scott Rahim – Connectivity Wireless Solutions



2018 BICSI Fall Conference & Exhibition



Bicsi

Mark Niehus, RCDD

Mark is Director of Strategic Accounts for CWS. With more than 25 years of ICT installation, project management, and sales and marketing experience, he uses his comprehensive industry knowledge to educate clients on in-building wireless approaches and solutions.

An RCDD since 1997 and as well as a veteran presenter to the BICSI community, Mark frequently presents updates on relevant topics for customer-specific seminars and is a published author and contributor for various industry publications.



2018 BICSI Fall Conference & Exhibition



Bicsi

Scott Rahim

As an RF engineer for Connectivity, Scott applies concentrated in-building wireless (DAS) knowledge to ensure best-in-class system design, performance and consistent RF engineering throughout the U.S.

With project experience spanning several industries—including hospitality, higher education, healthcare, commercial, industrial, and sporting and entertainment—Rahim has designed, engineered, commissioned and managed some the nation's most complex venues, while providing extensive customer support throughout the duration of each project.

Rahim is certified in all major DAS technologies.



2018 BICSI Fall Conference & Exhibition



Bicsi

Connectivity Wireless Solutions is an industry-leading technology solutions provider.

With more than 450 years of combined industry experience, and one of the first companies to break into the DAS industry, Connectivity has provided thousands of unique solutions to meet the wireless needs of venues and facilities throughout the U.S. since 2008.

Having integrated systems across virtually every market and industry, Connectivity takes pride in matching each customer with exactly the right technology to ensure that its wireless and IT network needs are met.



2018 BICSI Fall Conference & Exhibition



Bicsi

Agenda

- Public Safety Primer
- Next Gen Wireless Trends
- Next Gen Wireless Solutions
- 15-minute break
- Infrastructure Deep Dive
- Carriers and Case Studies



2018 BICSI Fall Conference & Exhibition



Bicsi

Public Safety Primer



2018 BICSI Fall Conference & Exhibition



Bicsi

DAS for Public Safety

Mandates for radio service for public safety

- ICC & NFPA codes mandate first-responder coverage
- 150+ local municipalities now mandate public safety coverage inside large buildings
- Indoor cellular/PCS service required for E911 location
- 700 & 800 MHz bands allocated for fire and police
- 400,000 E911 calls per day (CTIA Semi-Annual Survey, Jan-June 2012)
- According the FCC, 70% of E911 calls are made from wireless phones
- FirstNet

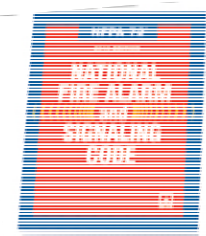

2018 BICSI Fall Conference & Exhibition



Bicsi

Public Safety DAS

NFPA Guidelines

- NFPA 72 2010
- Issued in April of 2009
- Only applicable if the municipality adopts this portion of the code

Require Public Safety coverage inside facilities for Fire, Police, First Responders

- No building size is identified – defines coverage
- If the municipality adopts the codes - it would be enforceable for new buildings and major renovations

Includes discussion on retransmission agreements

- Public Safety officials want permission before rebroadcasting
- Poor designs can harm coverage



Public Safety DAS

- 99% coverage in critical areas include command center, elevator lobbies, and exit stairs
- 90% coverage for remaining areas
- Component enclosures in NEMA 4/4X type enclosure
- Repeater equipment shall be FCC approved and certification
- UPS requirements
 - Primary is dedicated branch circuit
 - Secondary is 12-hour battery backup
- Annual testing required for active components and system



2018 BICSI Fall Conference & Exhibition



Bicsi

Public Safety DAS Construction

- Build systems to meet public safety enhancement system code requirements
- Close coordination with AHJ for specific building permit requirements
- NEMA 4 or 4X rated equipment enclosures
- Installation to NEC and BICSI standards
- **Parallel or combined carrier/public safety DAS system construction considerations employed during design and installation phases**
 - Physical separation of carrier and public safety infrastructure
 - Cost effective cable routing and management
 - Centralized vs. localized battery back-up



Getting AHJ approval

COORDINATION:

- Radio shop UL measurements
- Fire Marshall on-site time/ walk-test
- Access to all critical areas of building
- Alarm demonstration

TEST FOR ACCEPTANCE:

- Walk the floor and randomly test radio
- Witness alarm activation at fire alarm control panel
- Donor site radio noise floor monitoring



NextGen Wireless Trends



2018 BICSI Fall Conference & Exhibition



Bicsi

The Big Picture

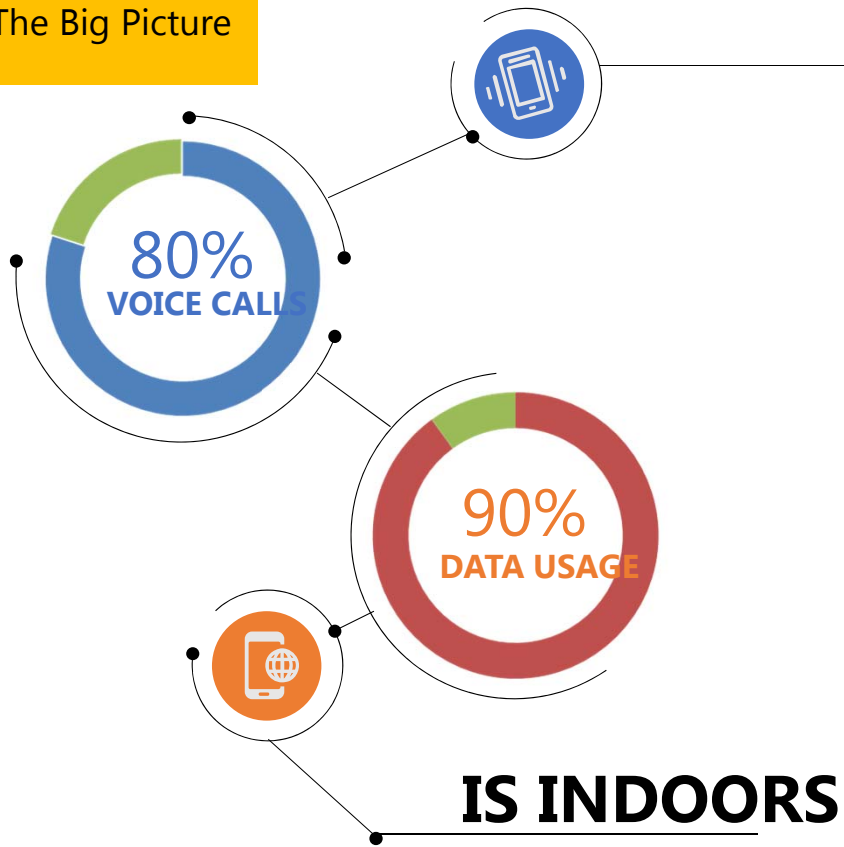

Today's **\$4.83 billion** in-building wireless market is expected to top **\$9 billion** by 2020

North America will continue to drive the **DAS market**



2018 BICSI Fall Conference & Exhibition



Future Technology Forecast



HERE TODAY

HERE TOMORROW

VoLTE
VoWLAN (Voice over Wireless LAN)
LTE Aggregation

IOT
5G

Emphasis on increased capacity.

Bulking up bandwidth and infrastructure



Future Technology Forecast



HERE TODAY **HERE TOMORROW**

VoLTE
VoWLAN (Voice over Wireless LAN)
LTE Aggregation

IOT
5G

Emphasis on
increased
Bulking up bandwidth and infrastructure

capacity

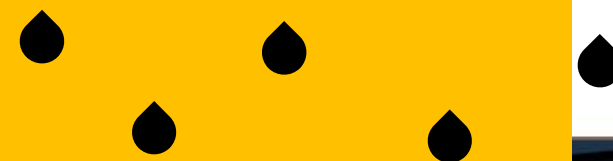

Internet of Things

A network of internet-connected objects ("things") able to collect and exchange data

24 billion IoT devices installed by 2020 with

\$6 trillion invested in IoT solutions over the next 5 years



say that by 2025, IoT will have widespread and beneficial effects on the everyday lives of the public



What are the best wireless networks for the IoT?

LR-WPAN

Wi-Fi

CELLULAR



LR-WPAN (IEEE 802.15.4)

COVERAGE IN AREAS INSIDE BUILDINGS

LOW POWER, LOW SPEED, LOW COST

- Bluetooth
- Zigbee
- Zwave
- WiSun
- Near Field Communications (NFC)

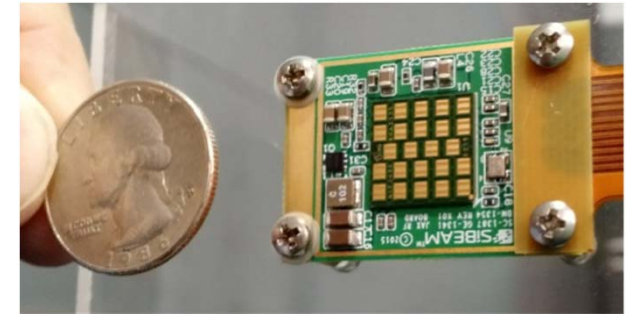

ZIGBEE SMART LIGHTING REFERENCE PLATFORM

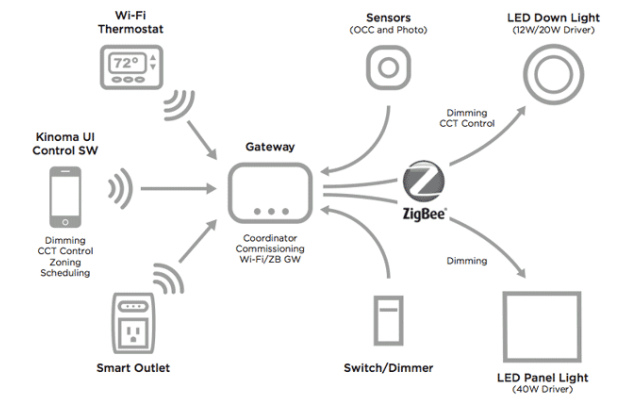

2018 BICSI Fall Conference & Exhibition



Bicsi

Coverage in every building

TODAY: 802.11n and 802.11ac

TOMORROW: 802.11ad

- 57-64 GHz (V band)
- 1-7 GBps ('fiber like')
- 10-20 meter range

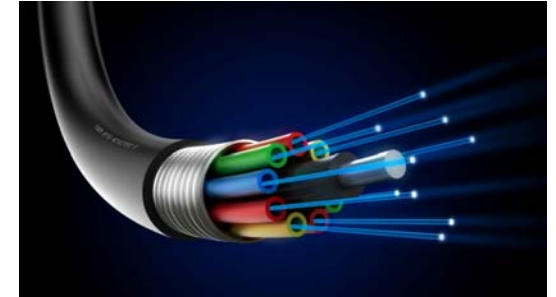

Cellular

Coverage wherever people are: inside and outside of buildings



SUPERCOMPUTER IN YOUR POCKET (4.7 HOURS PER DAY)

- Real-time language translation
- Augmented virtual reality (Oculus Rift)
- The Tricorder Project

SELF-DRIVING CARS

ROBOTS AND OTHER ASSISTANT DEVICES



2018 BICSI Fall Conference & Exhibition



Bicsi

Internet of Things: Impact

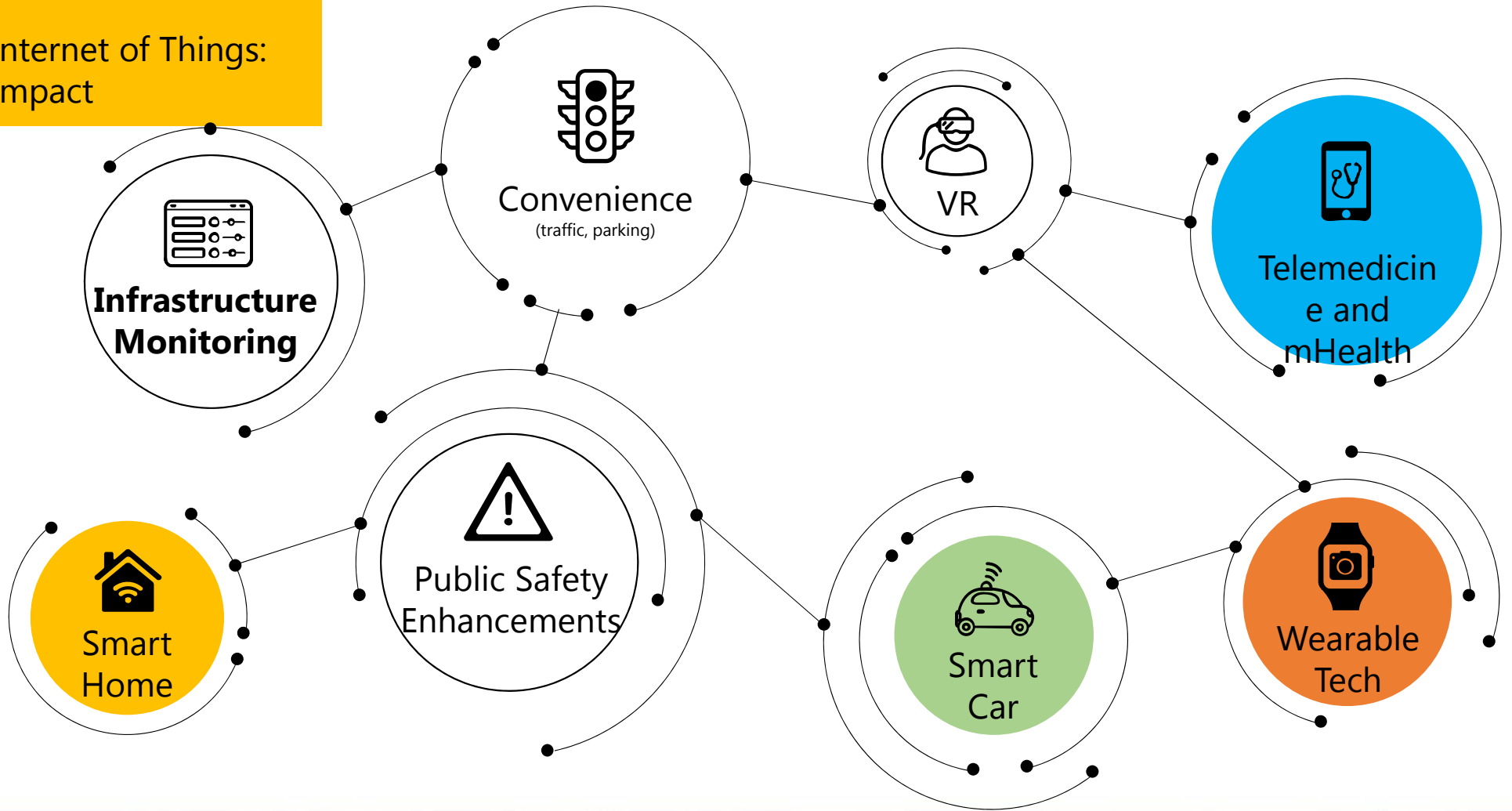

5G

Not one specific technology,
but a standard of service

3 KEY CONSUMER BENEFITS OF 5G



2018 BICSI Fall Conference & Exhibition



Bicsi

5G: What is the migration path to 5G?

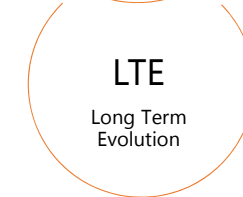
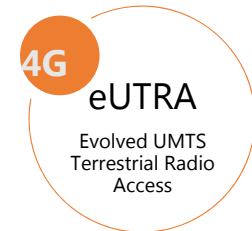
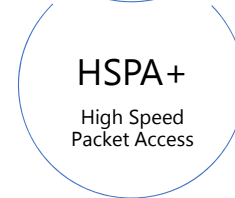
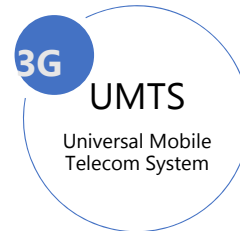

5G: A New Standard in Quality

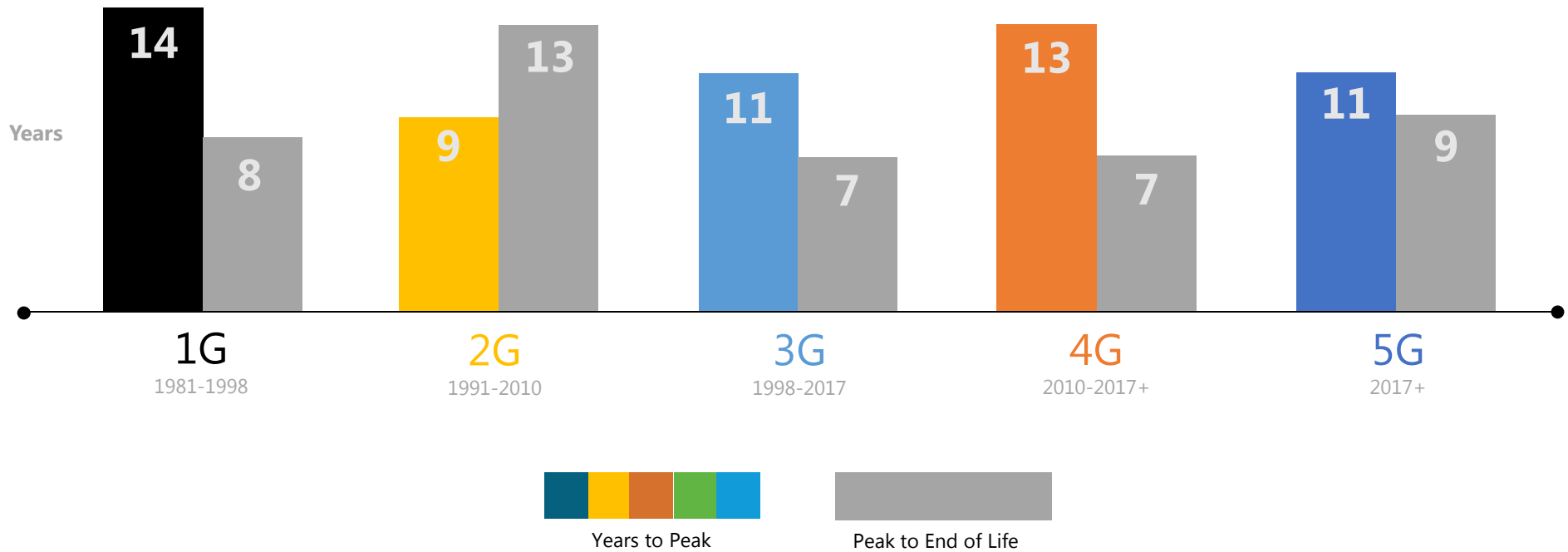

2018 BICSI Fall Conference & Exhibition



Bicsi

5G: A New Standard in Quality



BRINGS MORE SPEED
(10 times faster)



CONNECTS MORE DEVICES
(100 times more)



ALLOWS FOR A MORE RESPONSIVE
NETWORK
**(5 times reduced end to end network
latency)**

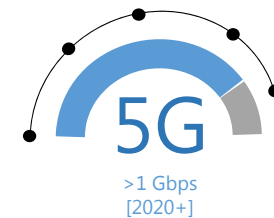
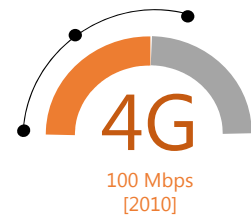
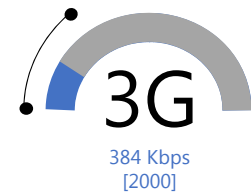

2018 BICSI Fall Conference & Exhibition



Bicsi

5G: What are the characteristics?

60 GHz and 70/80 GHz (millimeter wave)

BEAMFORMING
(**carrier aggregation, VoLTE, RCS**)

SUBJECT TO RAIN FADE
(**Also foliage, atmosphere**)

SHORT RANGE

HIGH DATA RATE
(**Gbps or “fiber like” speeds**)

MASSIVE MIMO



Beamforming, or spatial filtering

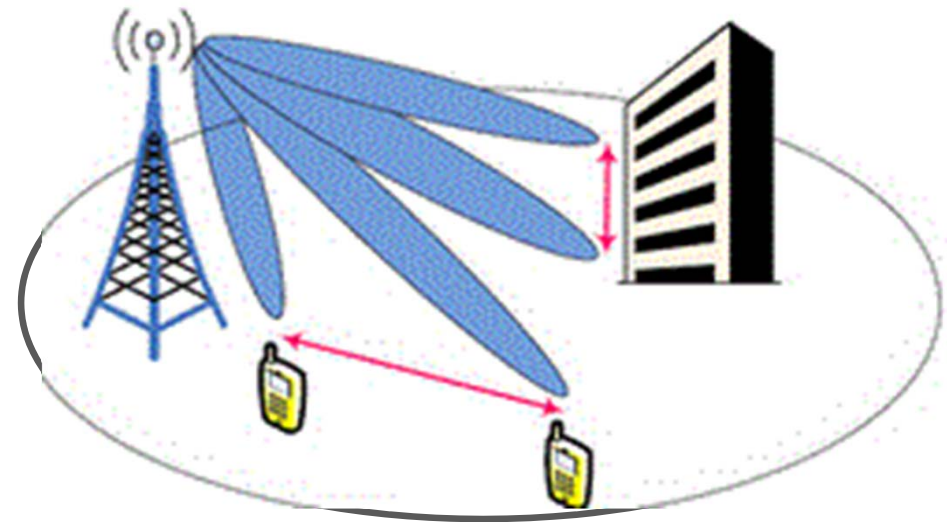

Used to improve gain over omnidirectional

- Technique used for directional signal transmission
- Combination of elements in a phased array in such a way that signals at particular angles experience constructive interference and others experience destructive interference



Massive MIMO

MORE ANTENNAS
(up to hundreds of antennas at base station)

SAMSUNG TEST PHONE WITH 32 LOW-
PROFILE ANTENNA ELEMENTS

POSSIBLY 5X THE SPECTRAL EFFICIENCY

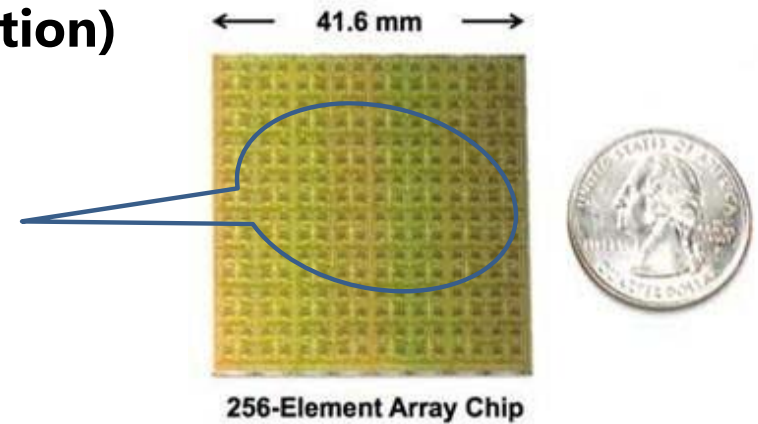

Massive MIMO

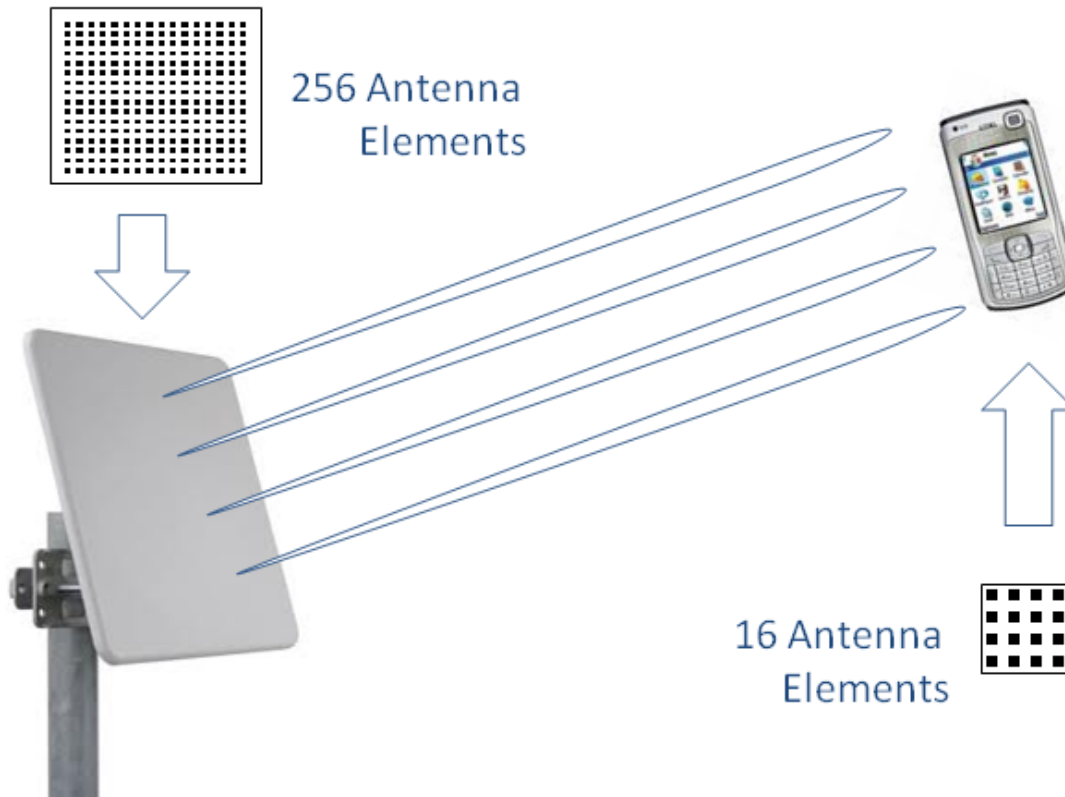

Massive MIMO

The architects are going to hate this...

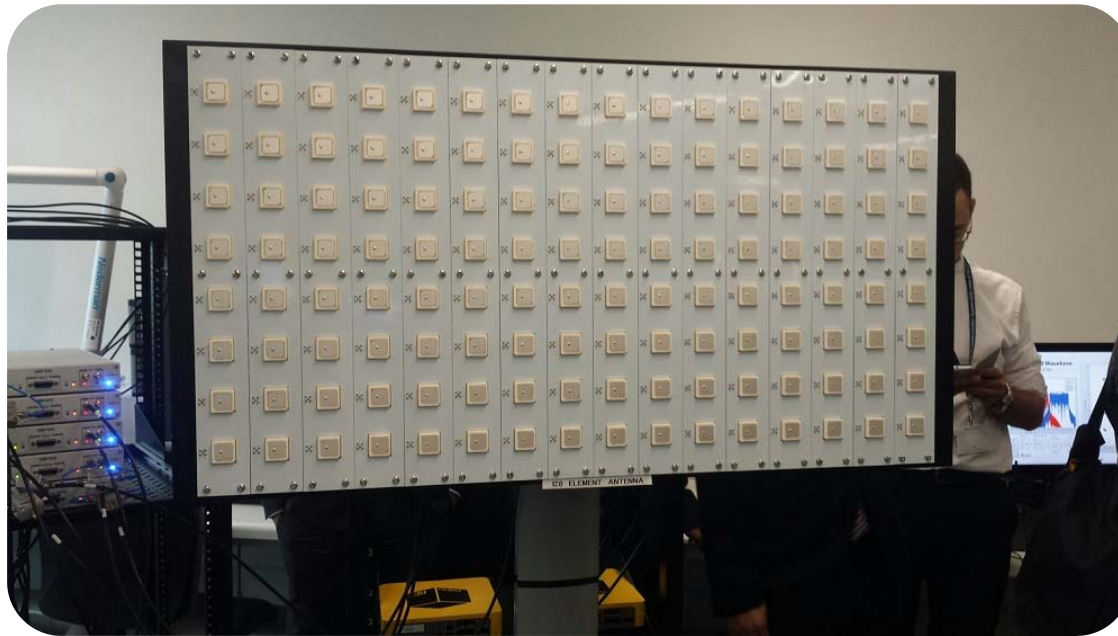

2018 BICSI Fall Conference & Exhibition



Bicsi

5G: What Are Carriers Doing?

- RESEARCHING 5G

- IMPROVING INFRASTRUCTURE
(carrier aggregation, VoLTE, RCS)

- EXPANDING INFRASTRUCTURE
(DAS, small cell)



Small Cells

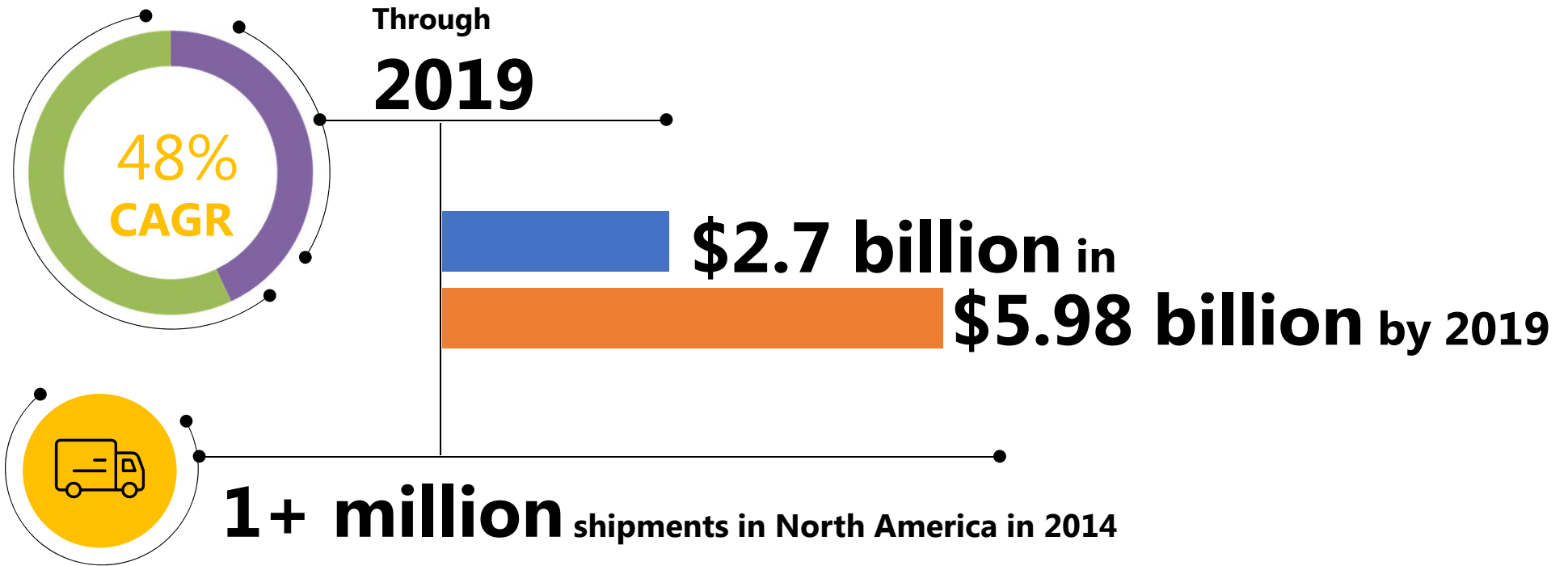

Deployments expected to double in subsequent years

Small Cells: Photos



2018 BICSI Fall Conference & Exhibition



Bicsi

Small Cells

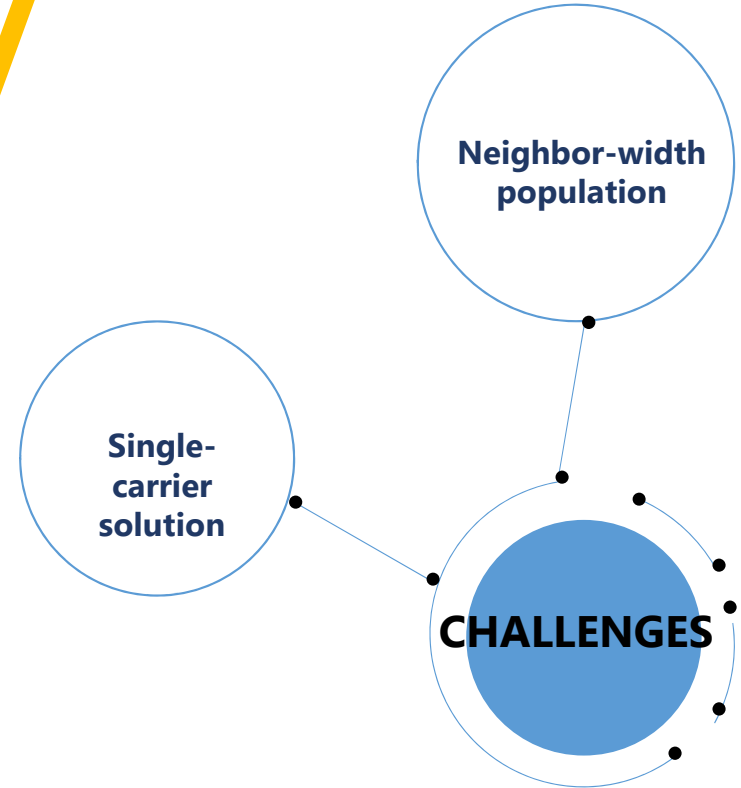
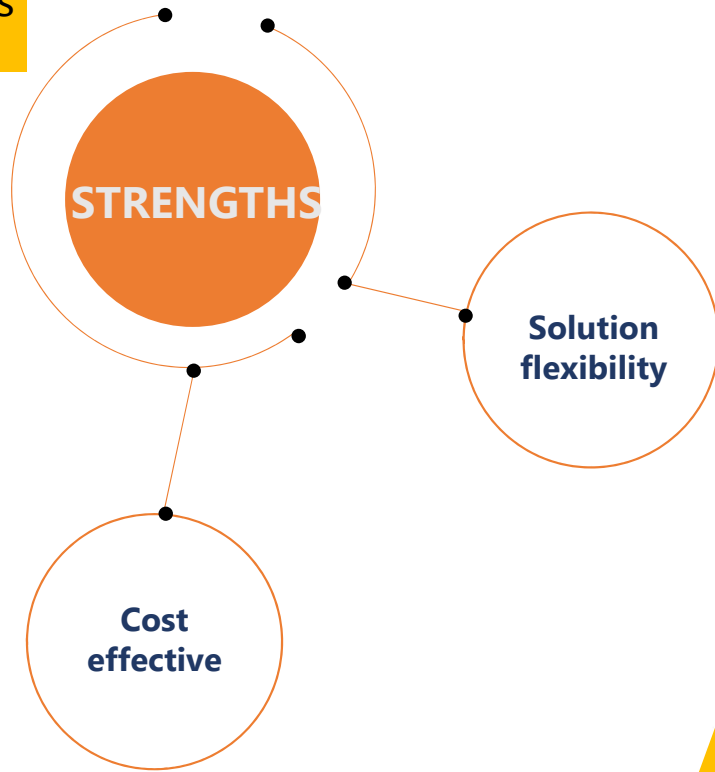

Virtual Reality

Changes the way we

WORK

PLAY

INTERACT



Virtual Reality: The Impact

- SOCIALIZED ONLINE WORK / TEACHING ENVIRONMENTS
- VIRTUAL DATING
- CULTURAL IMMERSION EXPERIENCES / TRAVEL
- TRAINING SIMULATIONS



The Tactile Internet

Waaaay out there...the tactile internet



2018 BICSI Fall Conference & Exhibition



Bicsi

The Tactile Internet



2017 Drivers

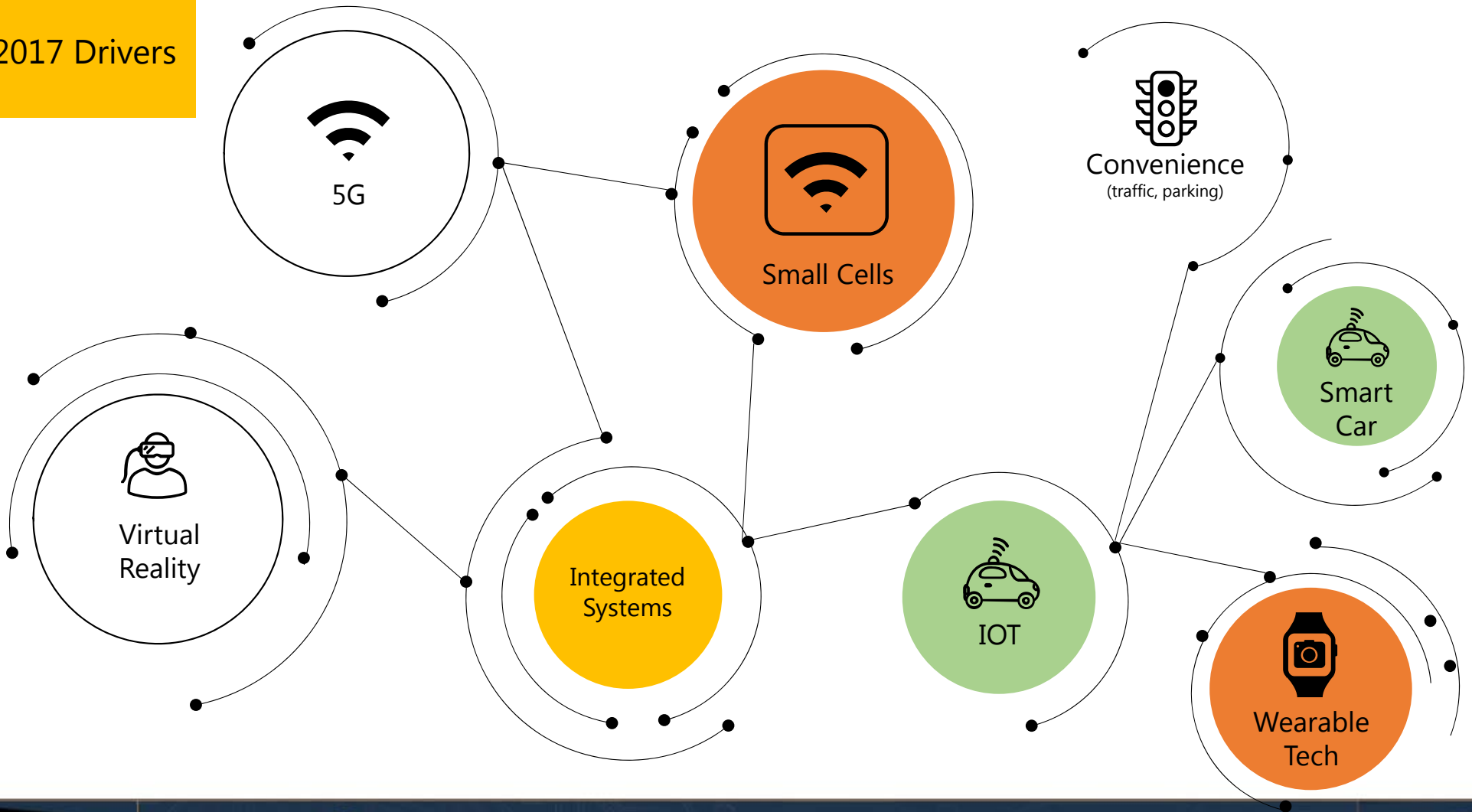

2018 BICSI Fall Conference & Exhibition



The Problem

less about
COVERAGE

more about
CAPACITY

One Simple Solution

DAS



2018 BICSI Fall Conference & Exhibition



Bicsi

NextGen Wireless Solutions



2018 BICSI Fall Conference & Exhibition



Bicsi

So,
why doesn't
my phone
work?

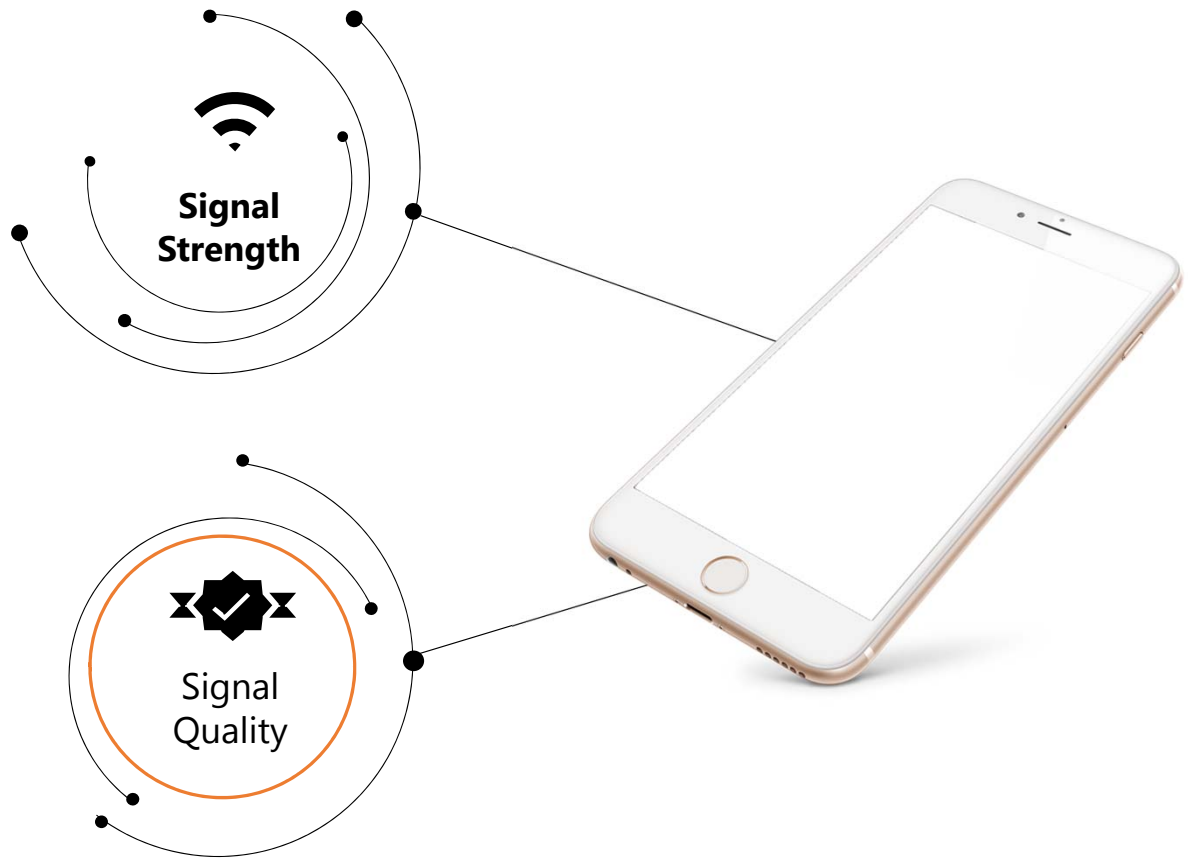

2018 BICSI Fall Conference & Exhibition



Bicsi

Signal Strength and Quality

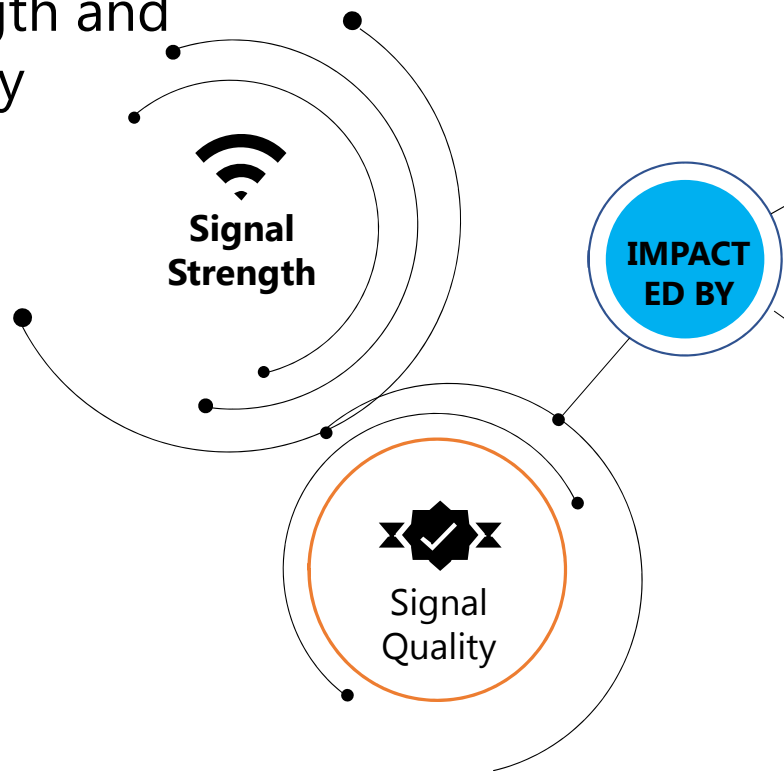

Noisy Environment



Capacity Limitations



2018 BICSI Fall Conference & Exhibition



**Signal
Quality
Noise**



**Signal
Quality
Noise**



**Signal
Quality
Noise**

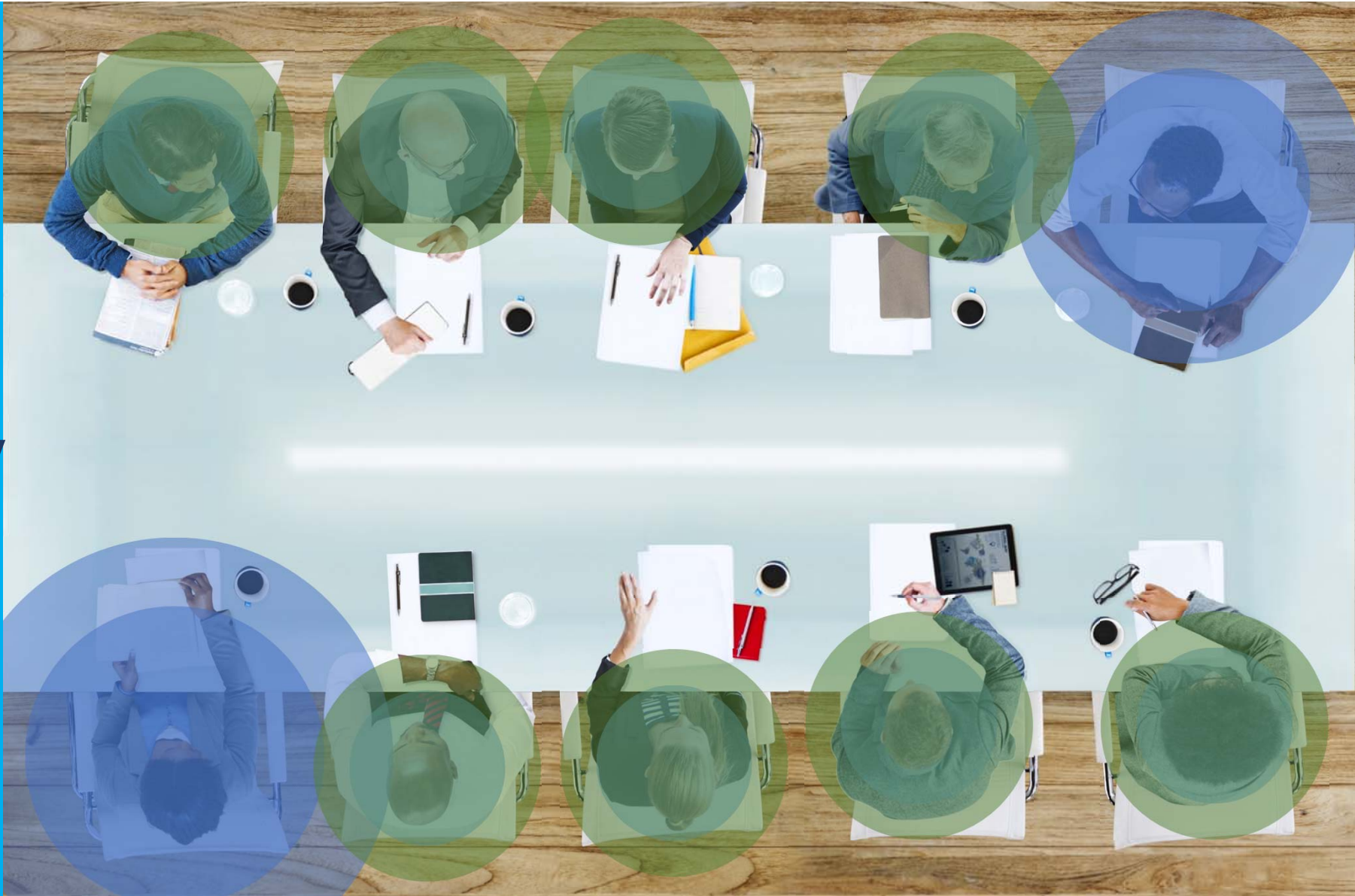

**Signal
Quality
Noise**



**Signal
Quality
Capacity**



**Signal
Quality
Capacity**



**Signal
Quality
Capacity**



Signal Quality Capacity



**Signal
Quality
Capacity**



Challenges for high-rise buildings

LOW E WINDOWS
(great for energy, bad for RF)

BASEMENTS, MECHANICAL AREAS,
CONCRETE WALLS

BUILDINGS IN-BETWEEN YOUR PHONE AND THE SERVICE
(often called a line-of-sight, or los, issue)

HIGH-RISE OFFICES OFTEN TOO FAR AWAY
FROM THE TOWER TO COMMUNICATE

TOO MANY NEARBY MACRO TOWERS
WITHOUT A DOMINANT SIGNAL

TOO MANY PEOPLE TRYING TO
USE THE SAME SIGNAL

NOISY ENVIRONMENTS
(pim, external interference, etc.)

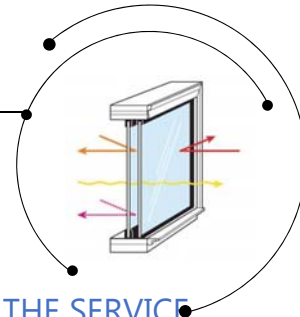

2018 BICSI Fall Conference & Exhibition



Bicsi

Network Improvements: What Are Carriers Doing About It?

CARRIERS IMPROVE THEIR MACRO
INFRASTRUCTURE AND FOOTPRINT

CARRIERS CAN BETTER UTILIZE THE
INFRASTRUCTURE THEY ALREADY
OWN



2018 BICSI Fall Conference & Exhibition



Bicsi



A properly designed, installed, commissioned, and maintained DAS solves every Signal Strength and Signal Quality issue.

CLEAN, CLEAR COMMUNICATION TO THE SOURCE.

Infrastructure Deep Dive



2018 BICSI Fall Conference & Exhibition



Bicsi

DAS Architecture Overview

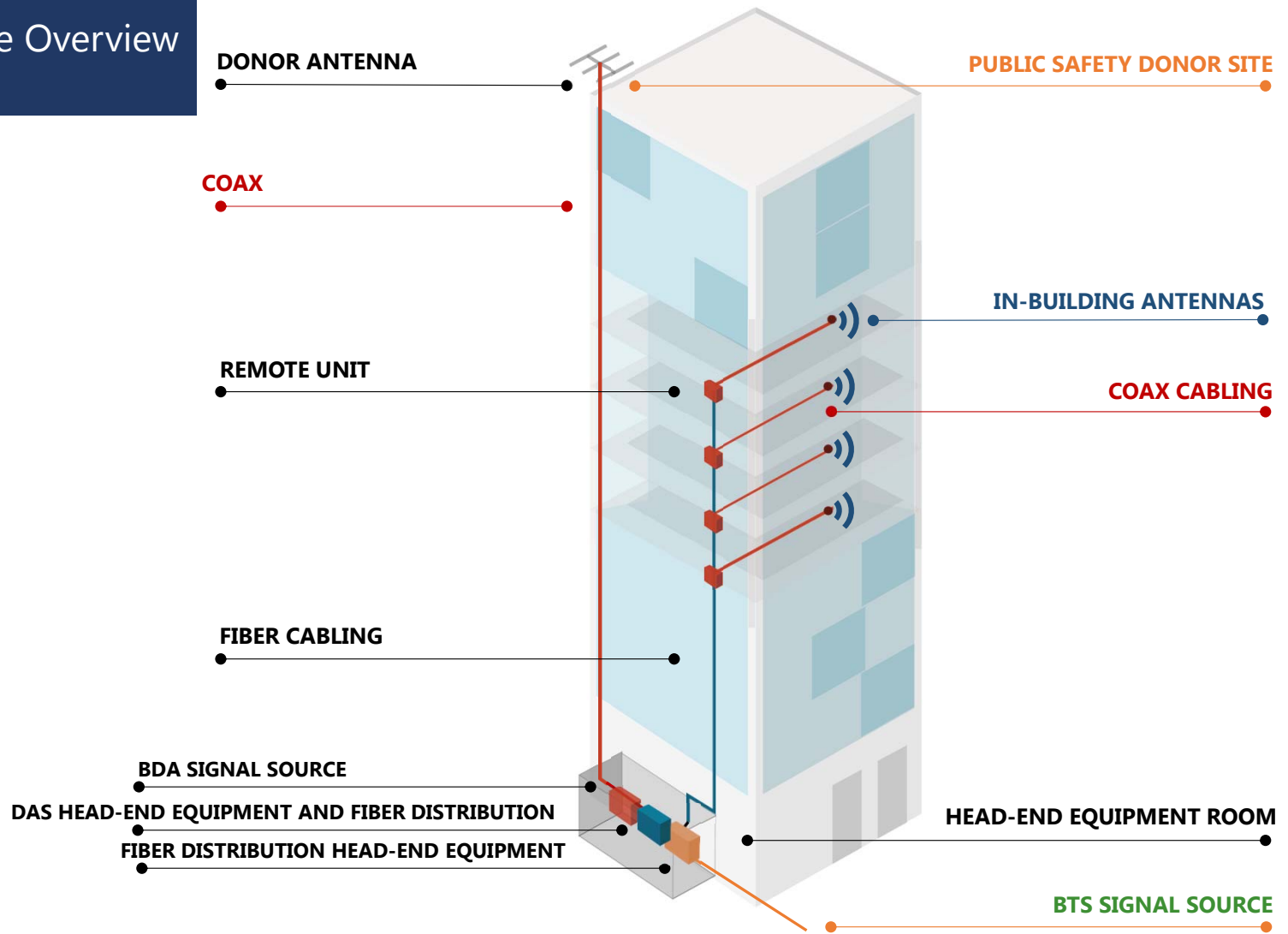

Traditional DAS Architecture

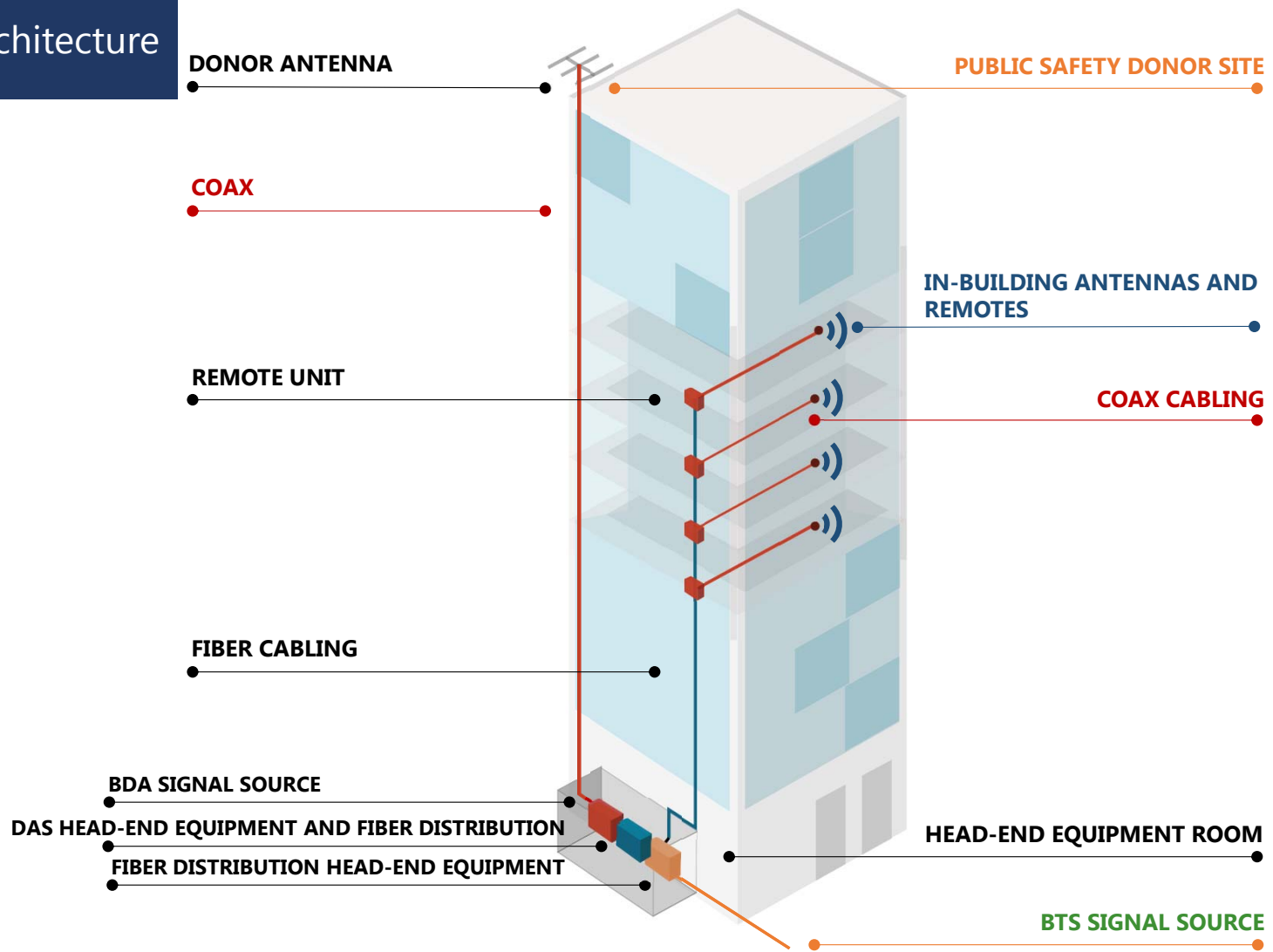

Fiber to the Edge Architecture

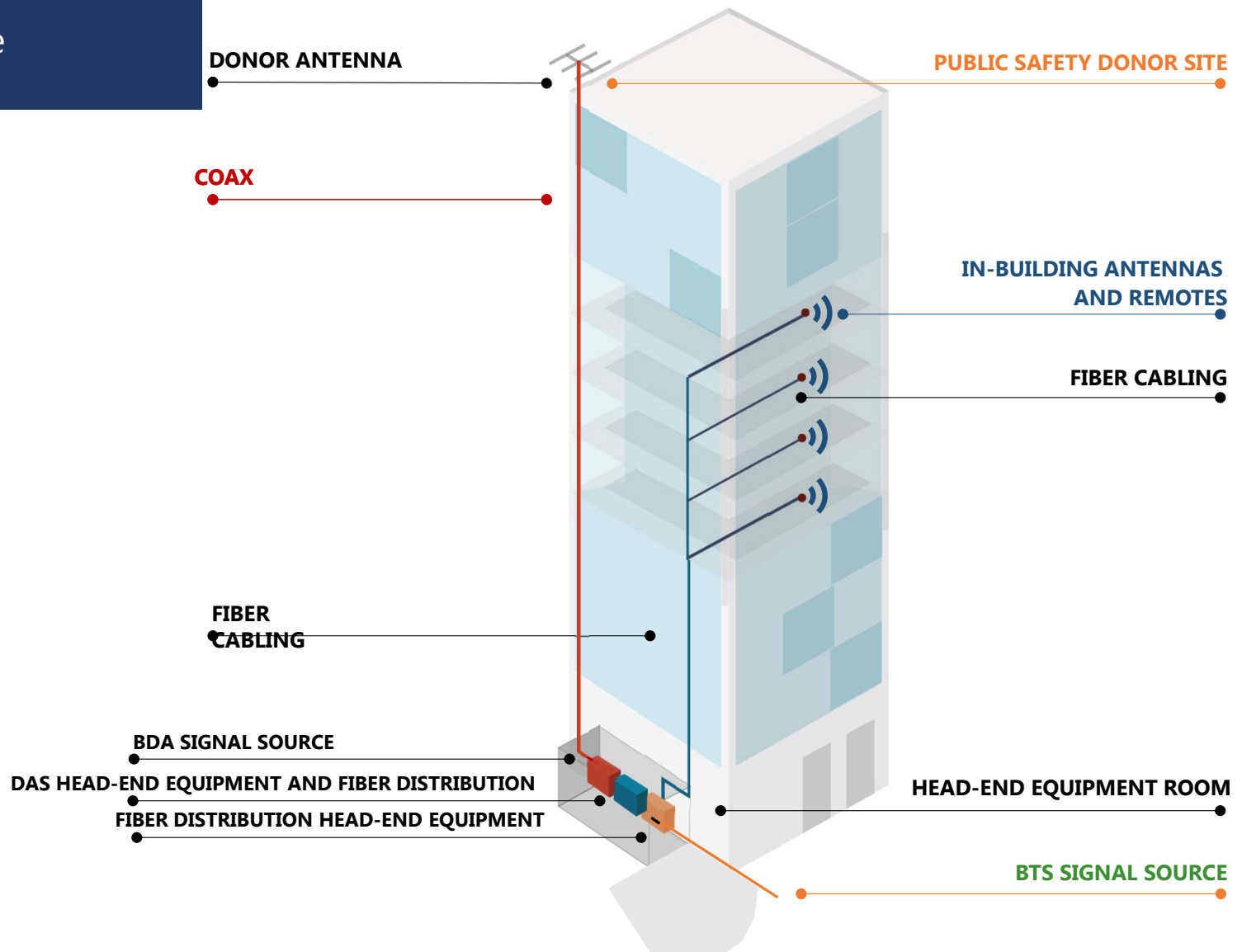

Players in the DAS Ecosystem

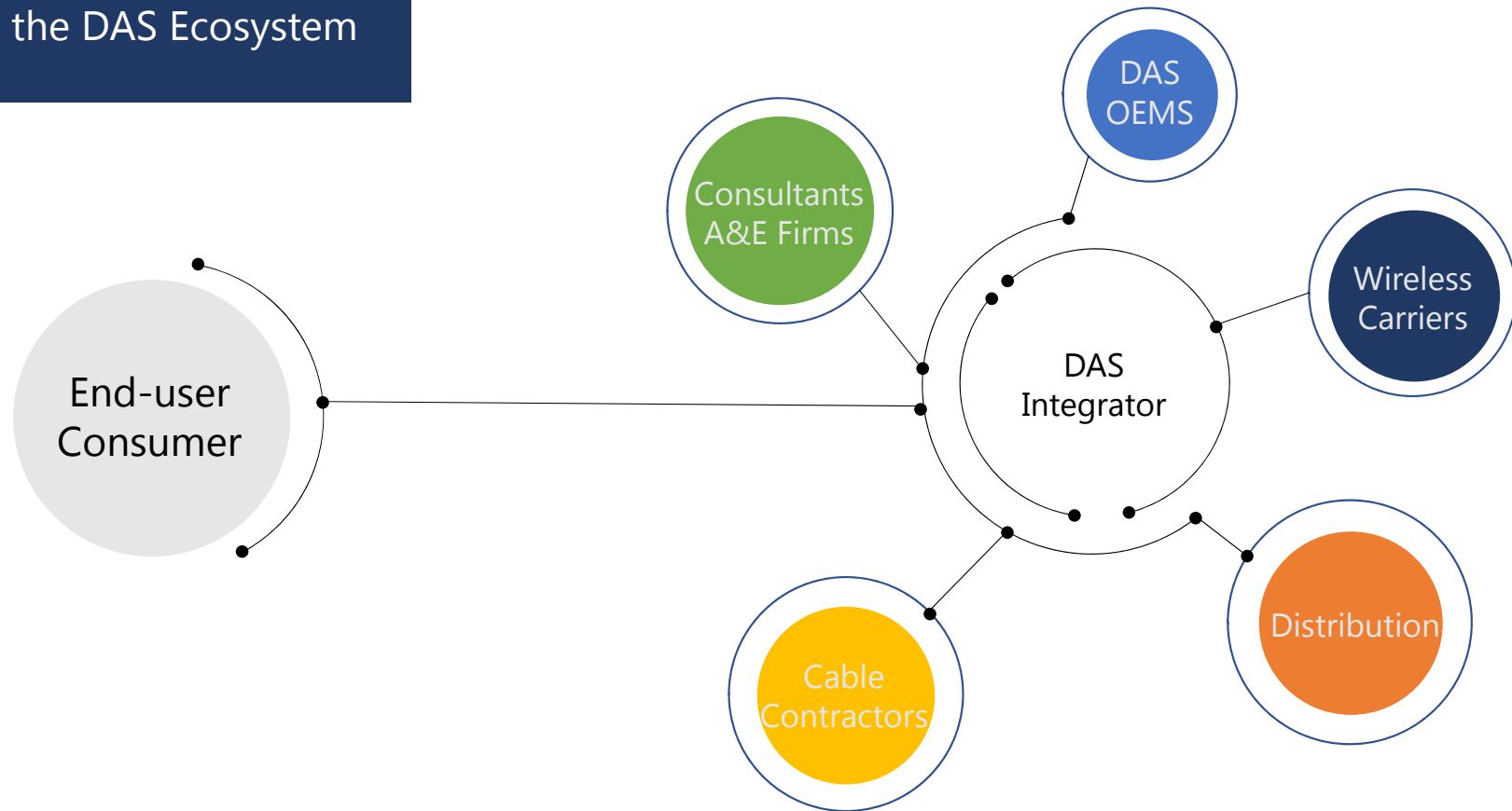

DAS Lifecycle

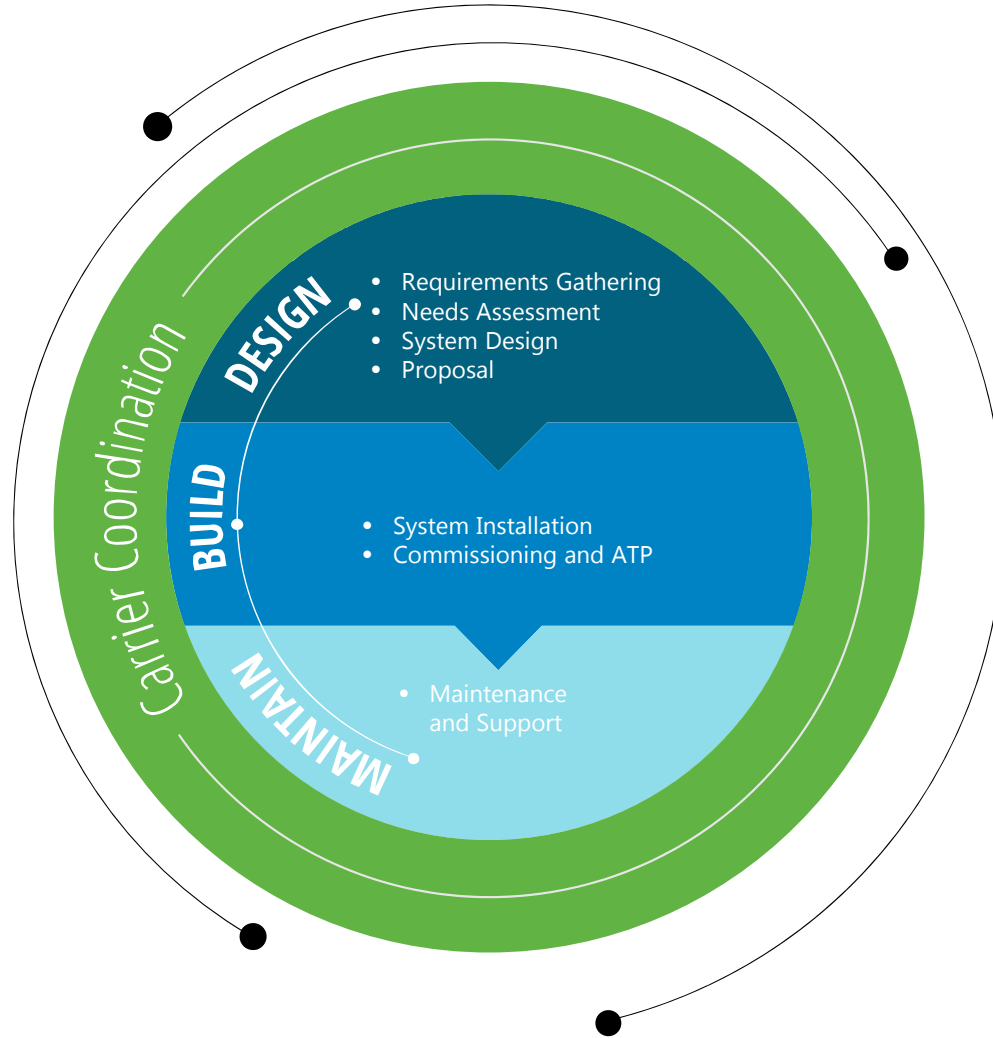

Collecting and Recording Carrier Data Helps With

CARRIER NEGOTIATIONS

PROPER DESIGN



Benchmark Data Collection

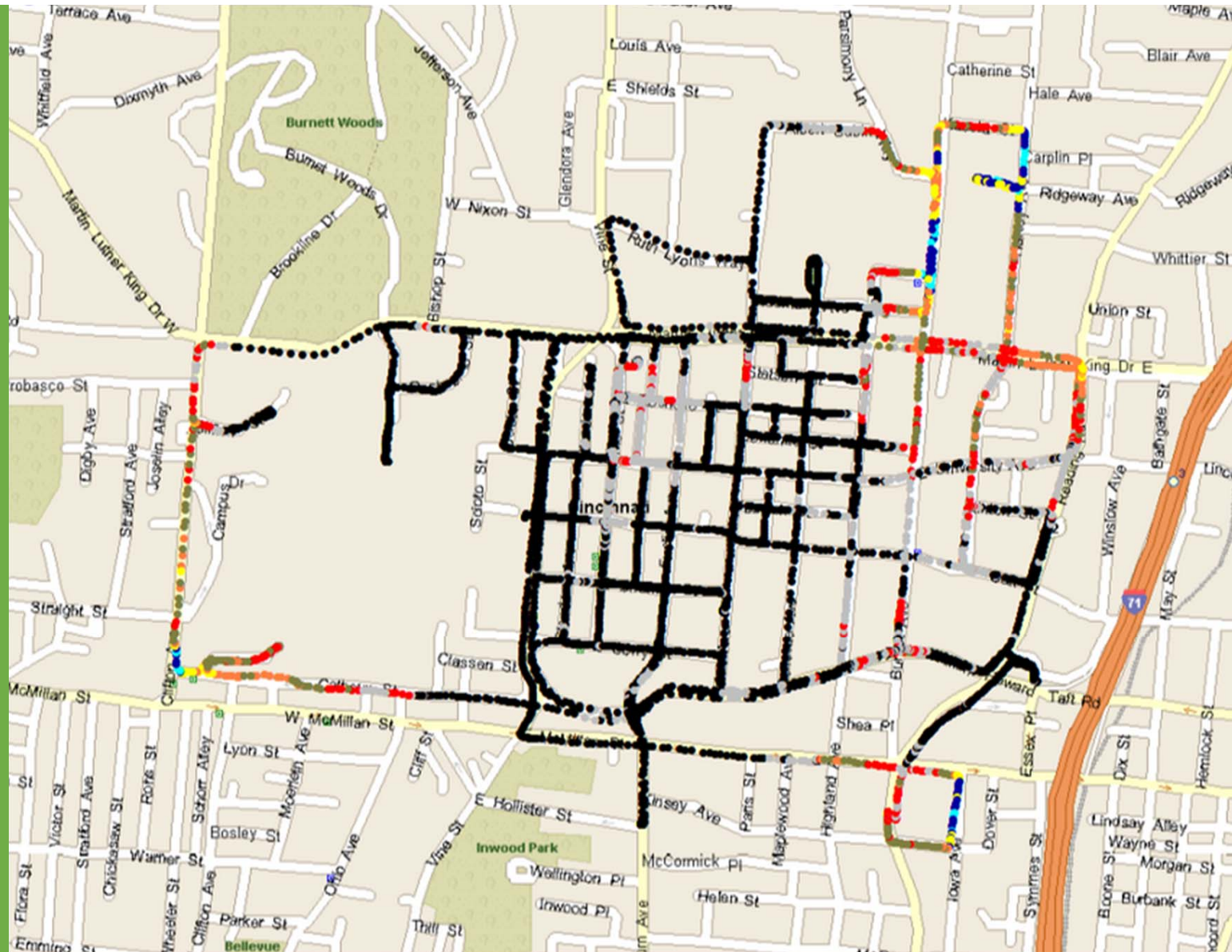
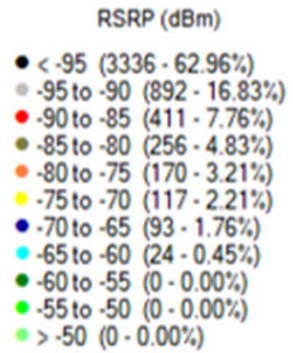

Benchmark Data Collection

Floor 24	Quality					
	Signal Level					
Floor 23	Quality					
	Signal Level					
Floor 22	Quality					
	Signal Level					
Floor 21	Quality					
	Signal Level					
		LTE 700	LTE 1900	LTE 2100	UMTS 850	UMTS 1900
		4G			3G	



AT&T

	Signal Level	Signal Quality
Good	Majority of Coverage Area -85dBm or better	-10dB or better
Marginal	Majority of Coverage Area between -85dBm and -95dBm	Between -10dB and -14dB
Poor	Majority of Coverage Area -95dBm or less	-14dB or less

Connectivity[™]
Wireless Solutions

Collecting and Recording the Characteristics of the Facility Helps With

PROPER DESIGN



Data Collection Example

Alerts

- ⊗ Blocked (0)
- ⚠ Dropped (0)
- 🚫 No Service (0)

Receive Power (dBm)

- -55 to -60 (36)
- -60 to -65 (83)
- -65 to -70 (139)
- -70 to -75 (179)
- -75 to -80 (147)
- -80 to -85 (127)
- -85 to -95 (40)
- -95 to -105 (22)

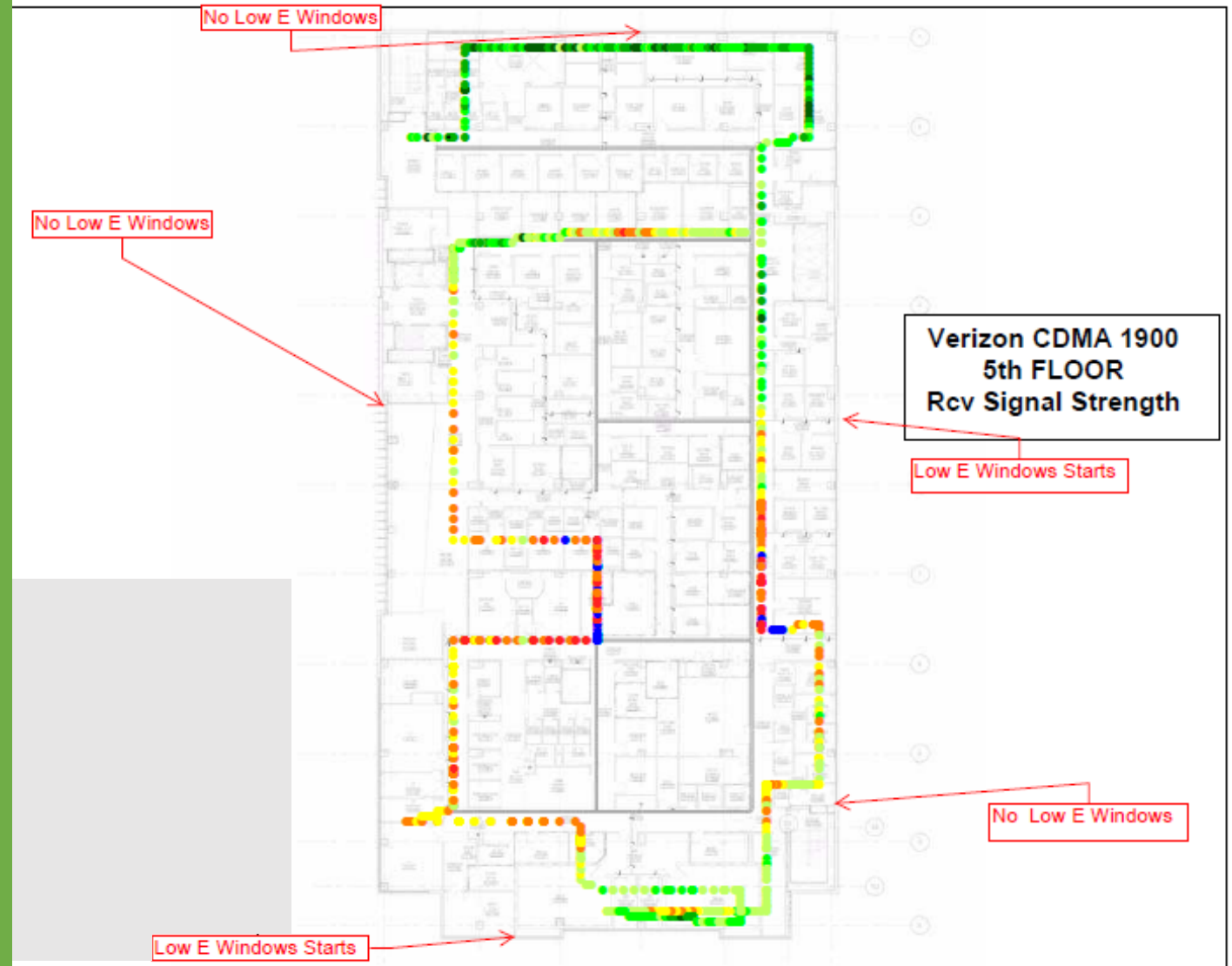

Site Survey

OBJECTIVE

To ensure that the system can be constructed per the specifications of the design and to help determine additional value engineering specifics.

RF OBSTACLES

INTERIOR WALL MATERIALS

CEILING HEIGHTS AND TYPES

PURPOSE OF BUILDING

VERTICAL CHASES



Design

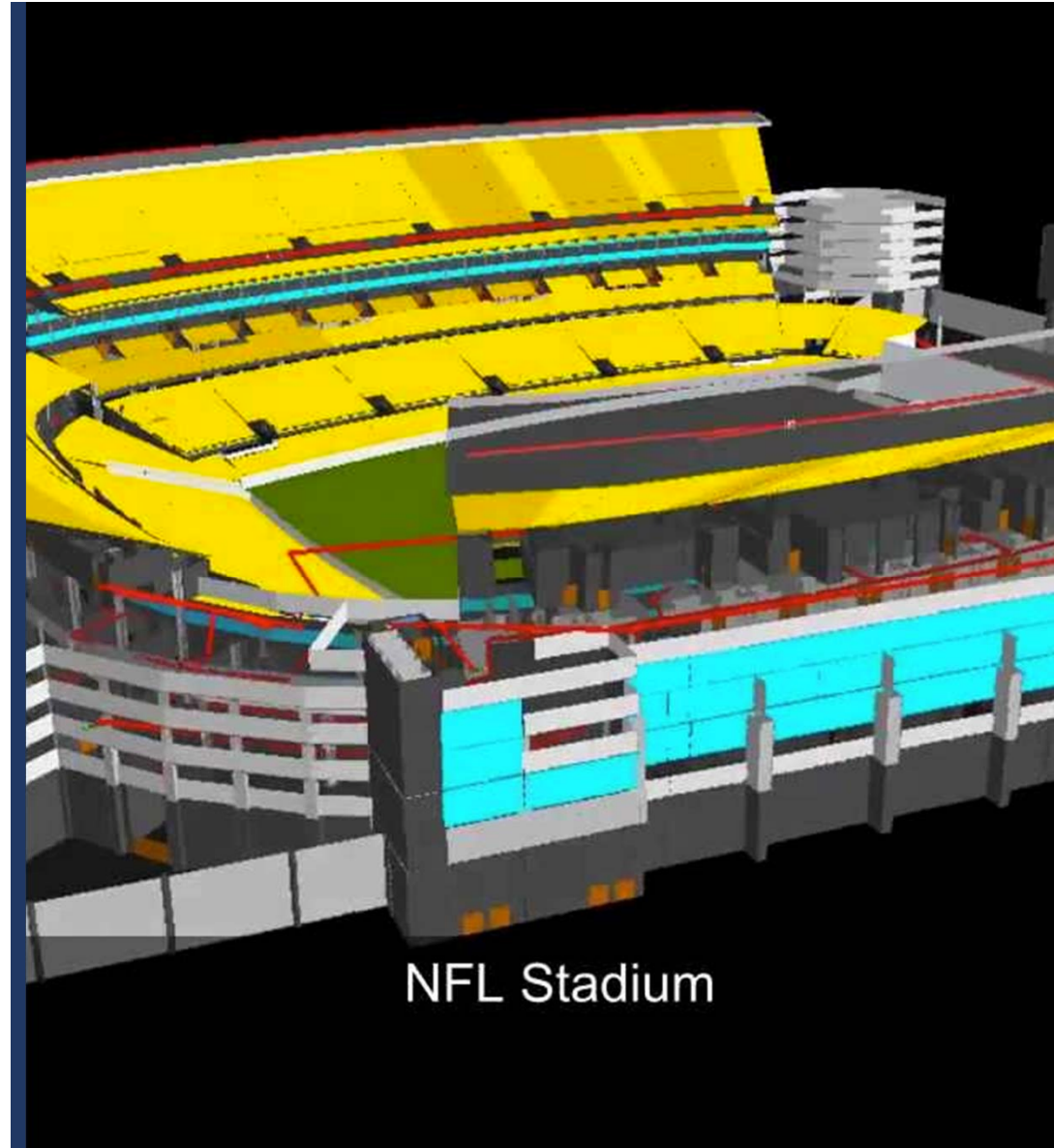

Wireless Design Thresholds

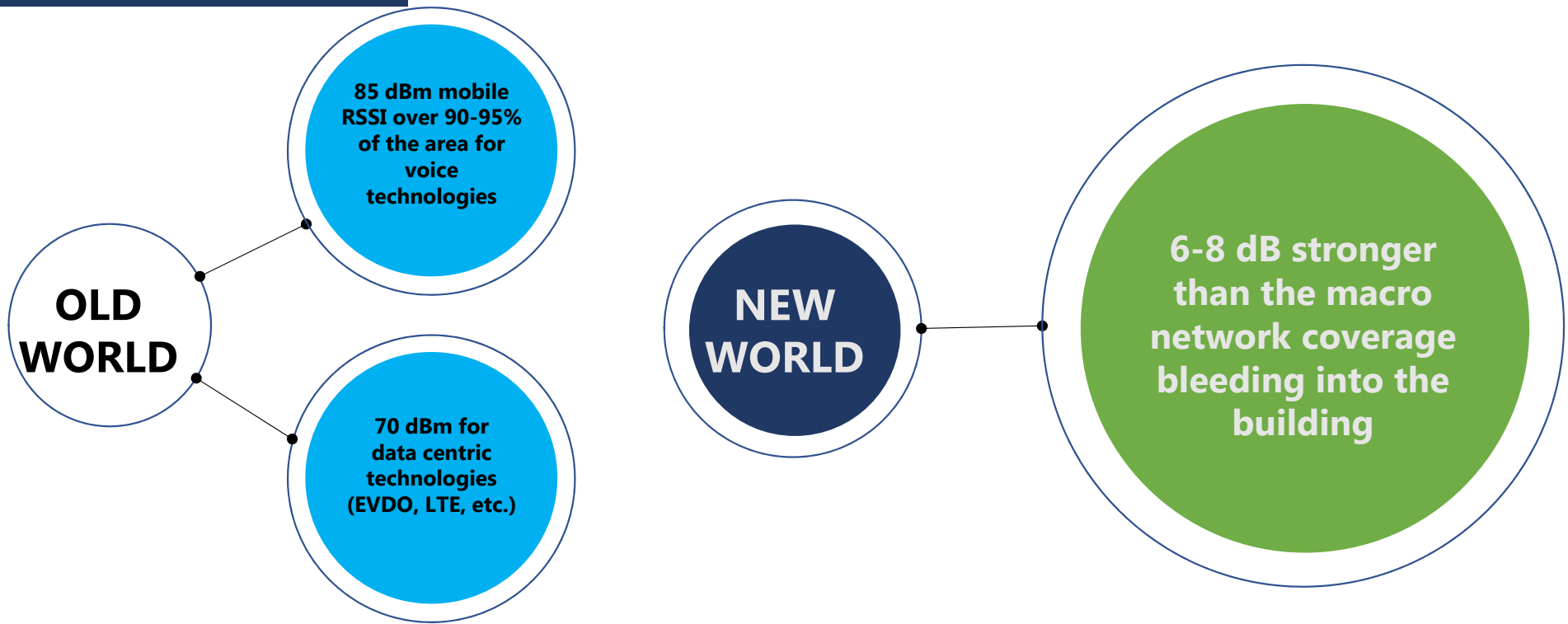

DAS

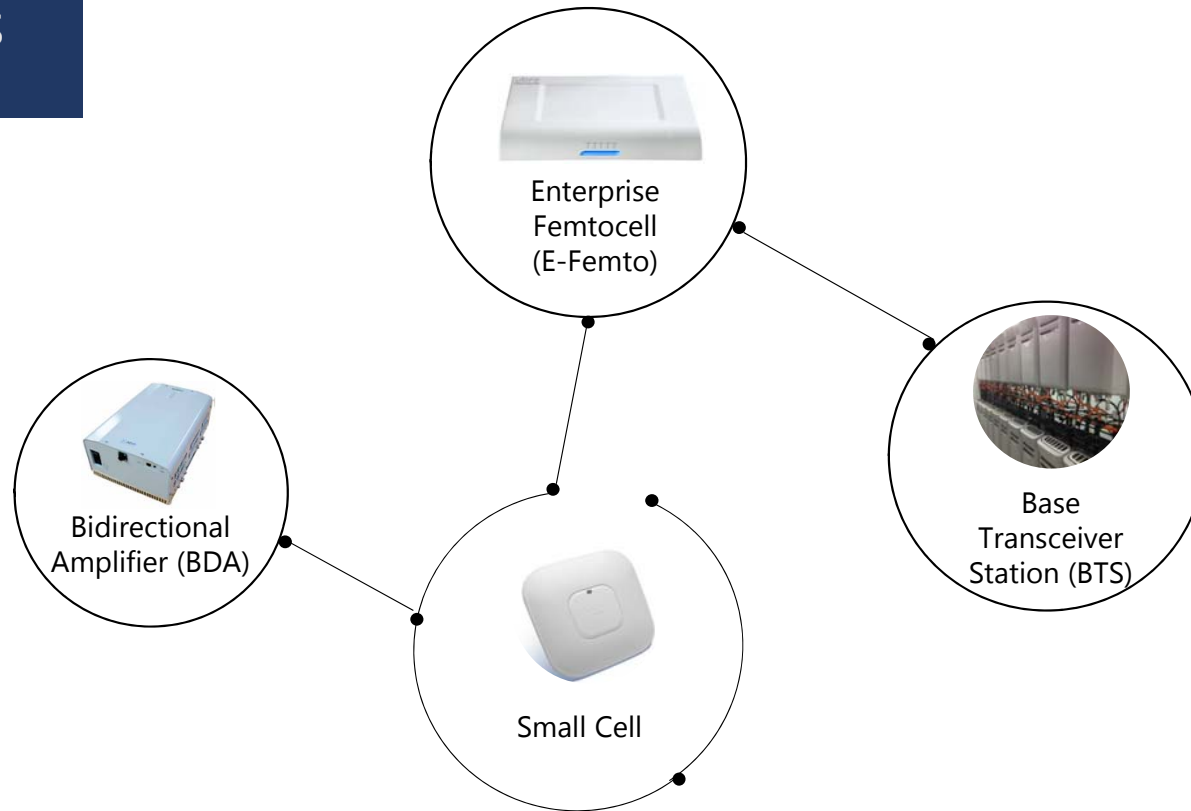

**RF Sources
– What am
I going to
connect to
the DAS?**



2018 BICSI Fall Conference & Exhibition



Bicsi

Design: 3D Modeling

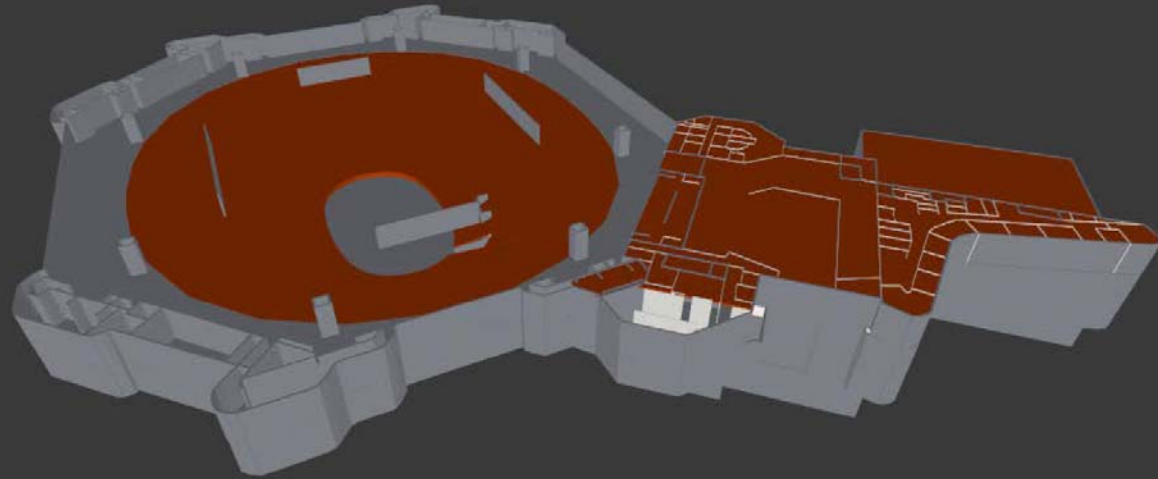
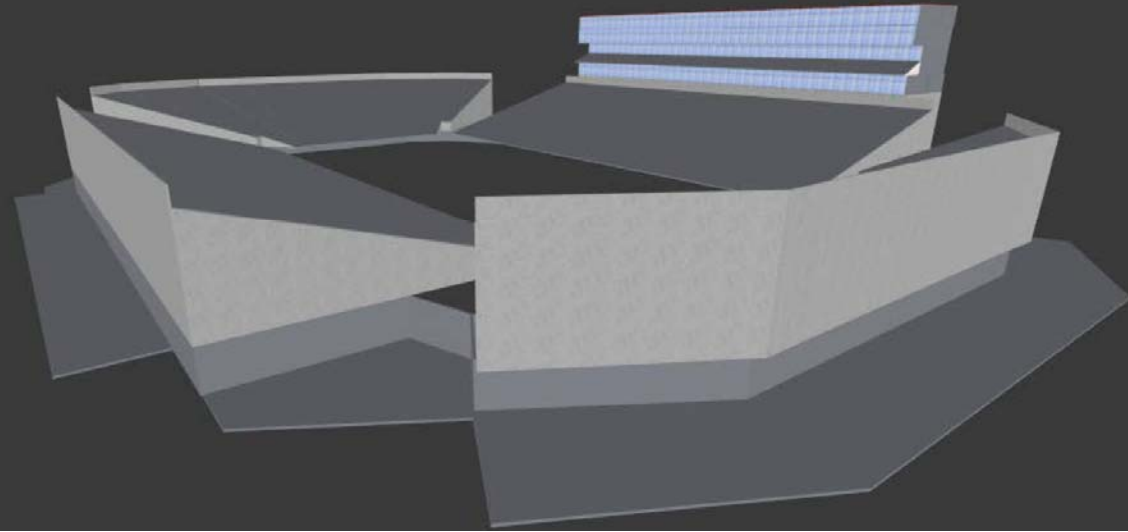
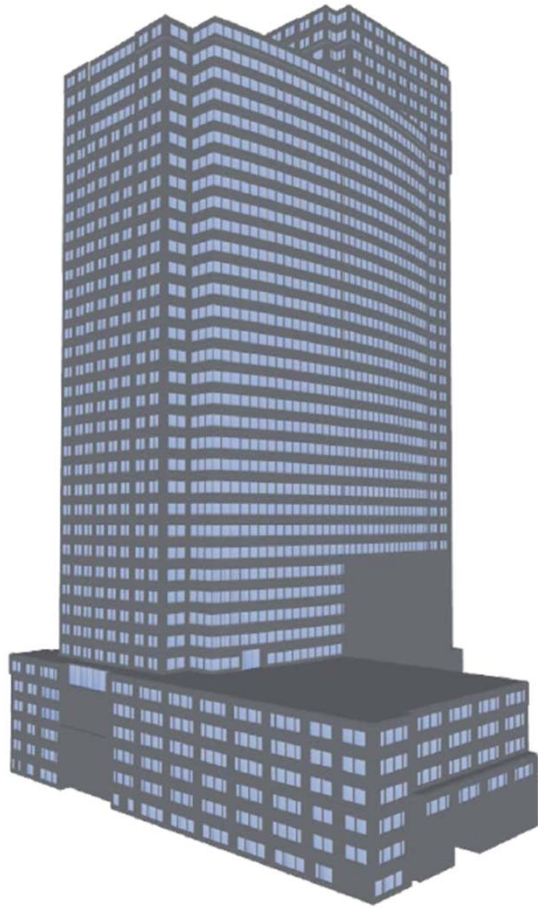

Design: Antenna Layouts

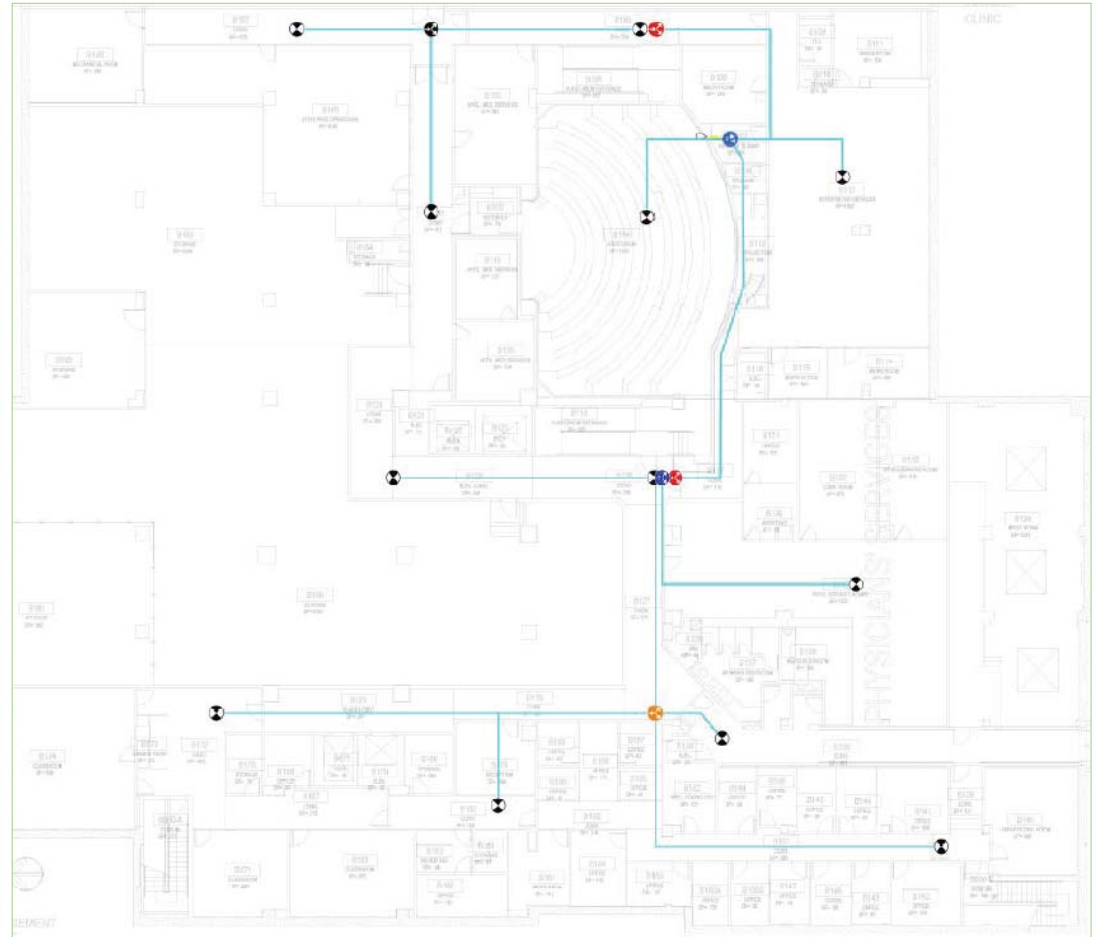
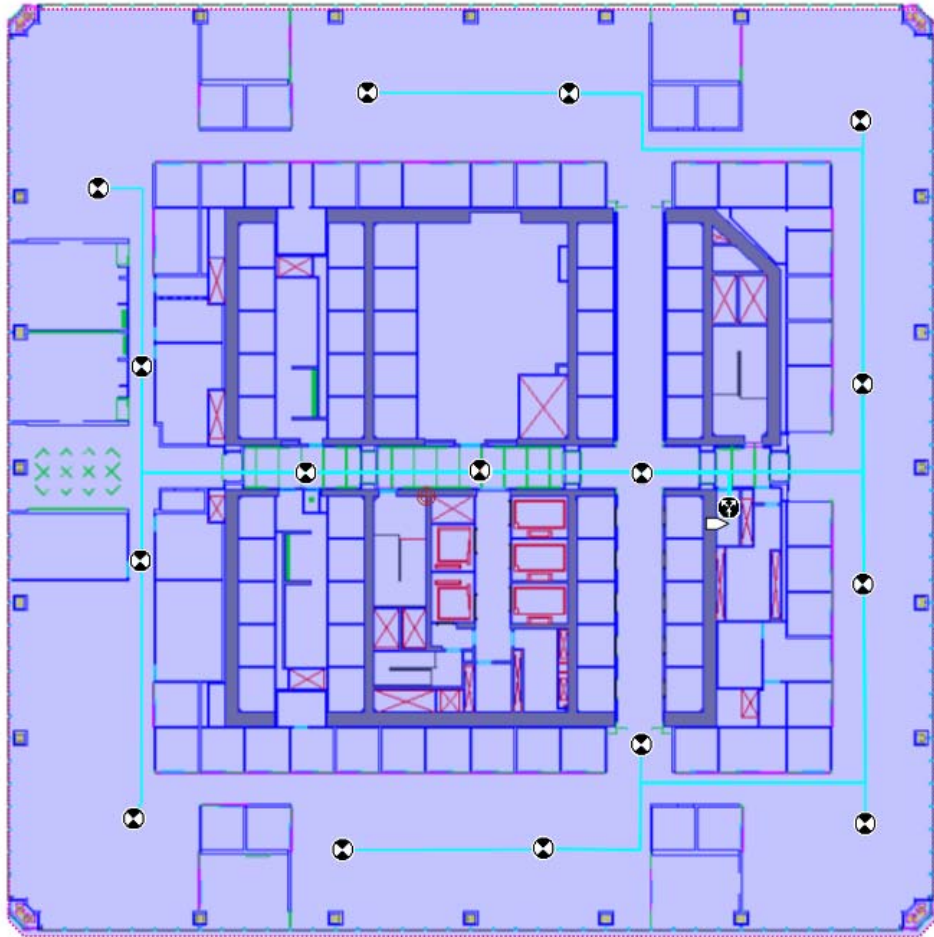

Design: Riser Diagrams

Lower Level 2

Lower Level 1

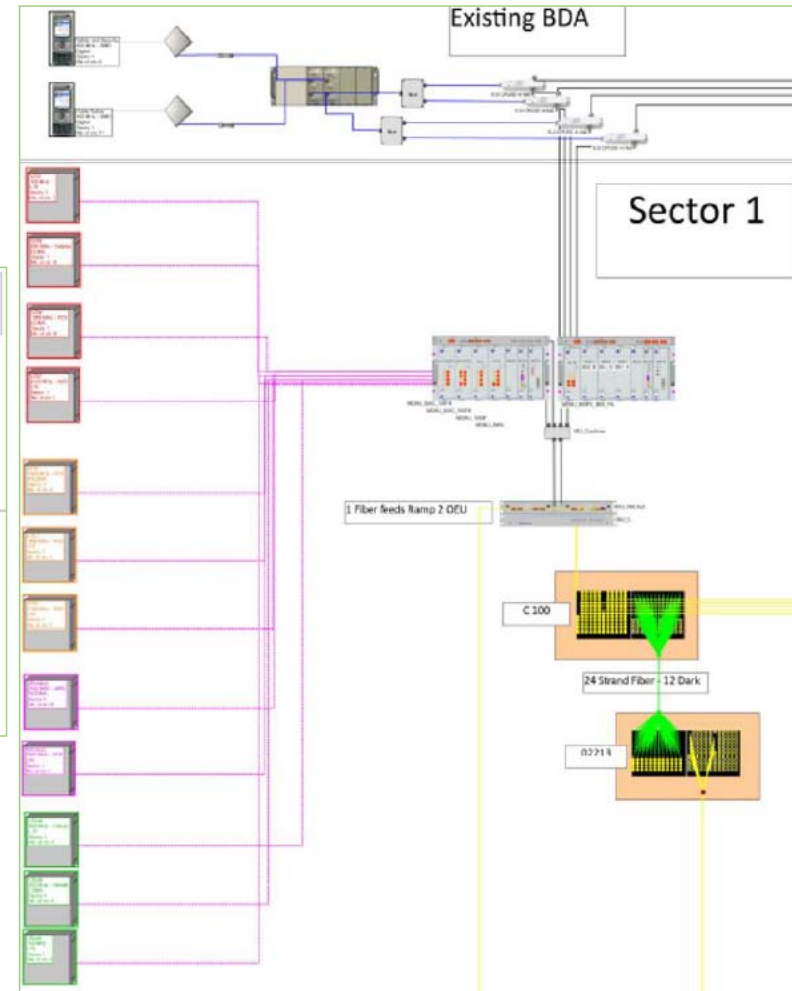

Design: Riser Diagrams

Tower	IDF's	Fiber Strands	Notes
1	16	32	Includes IDF in the Podium and 49th Floor for BDA
2	10	20	No IDF in the Podium
3	12	24	Includes IDF in Podium

Total 38 76

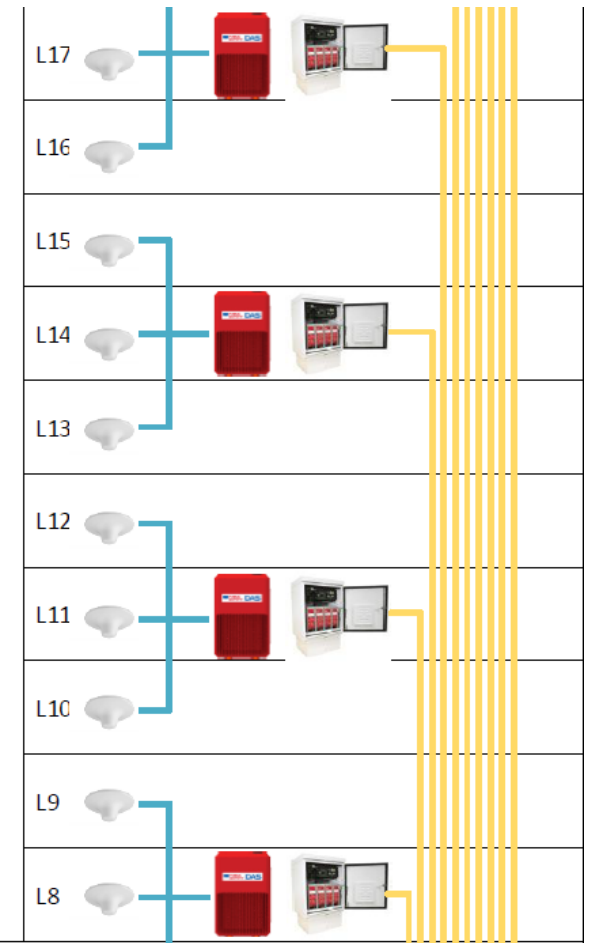
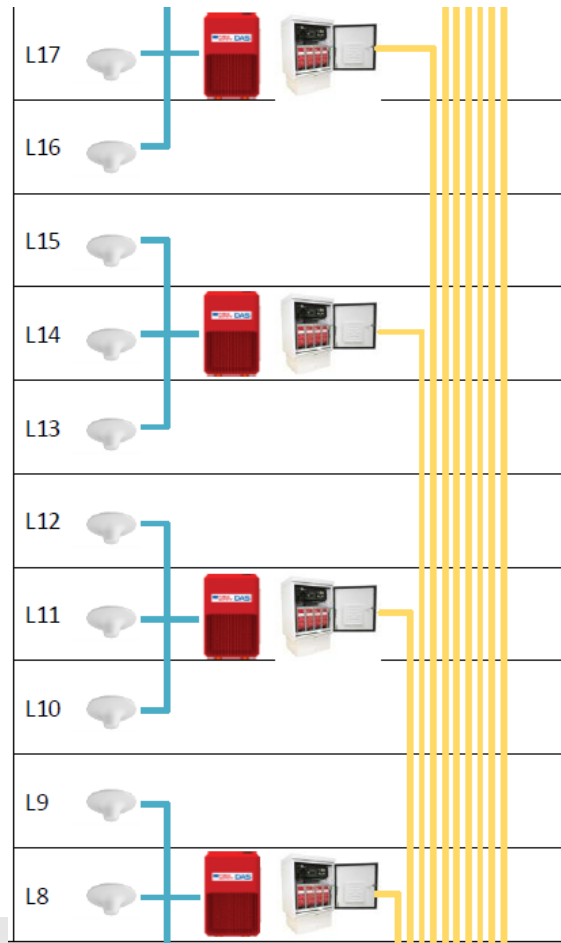

Design: Prediction Plots

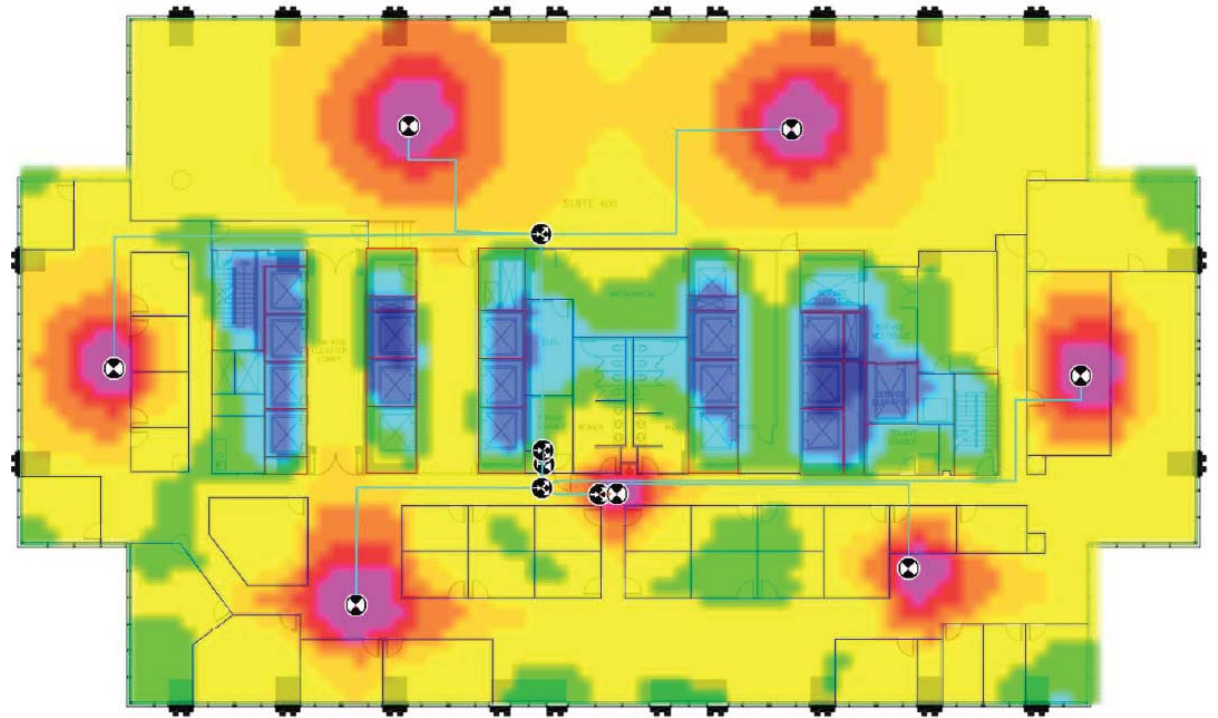
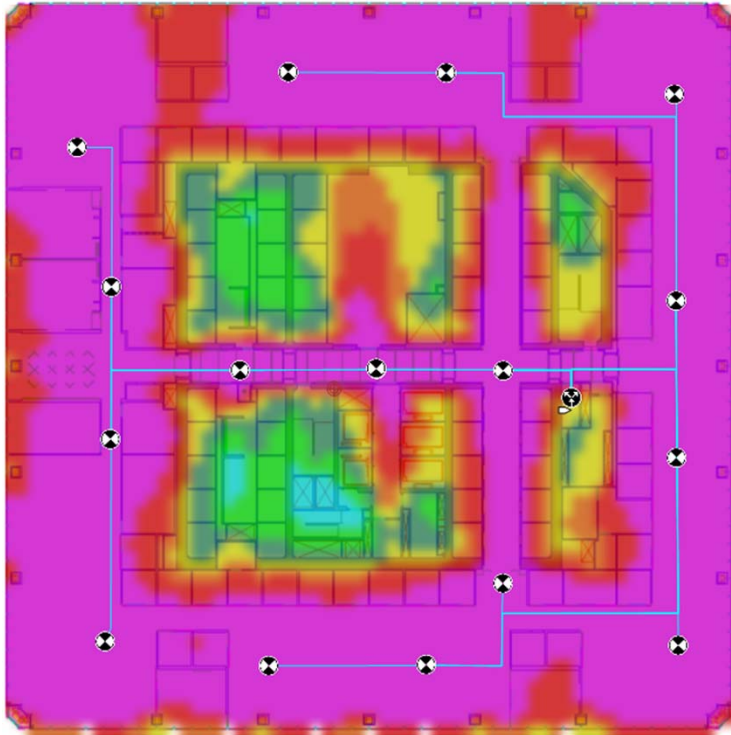

Design: Prediction Plots

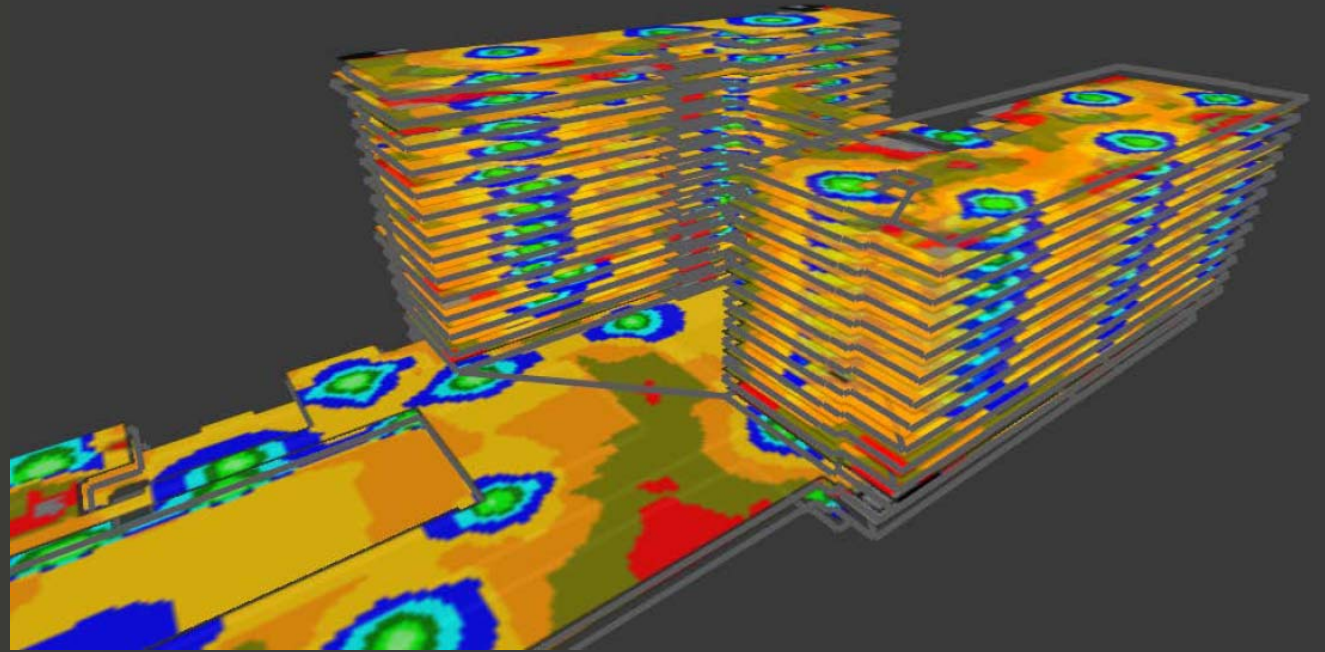
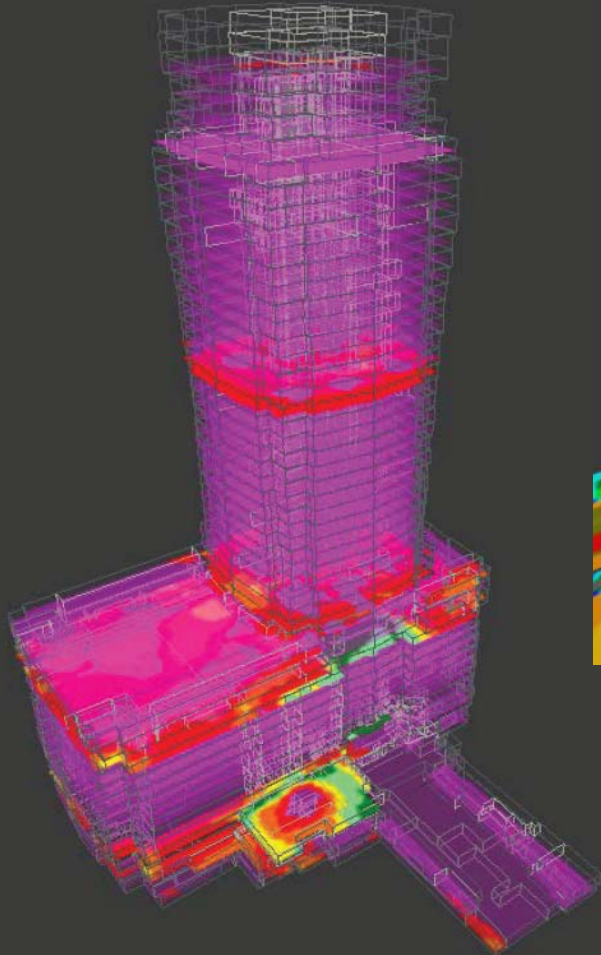

Design: Prediction Plots

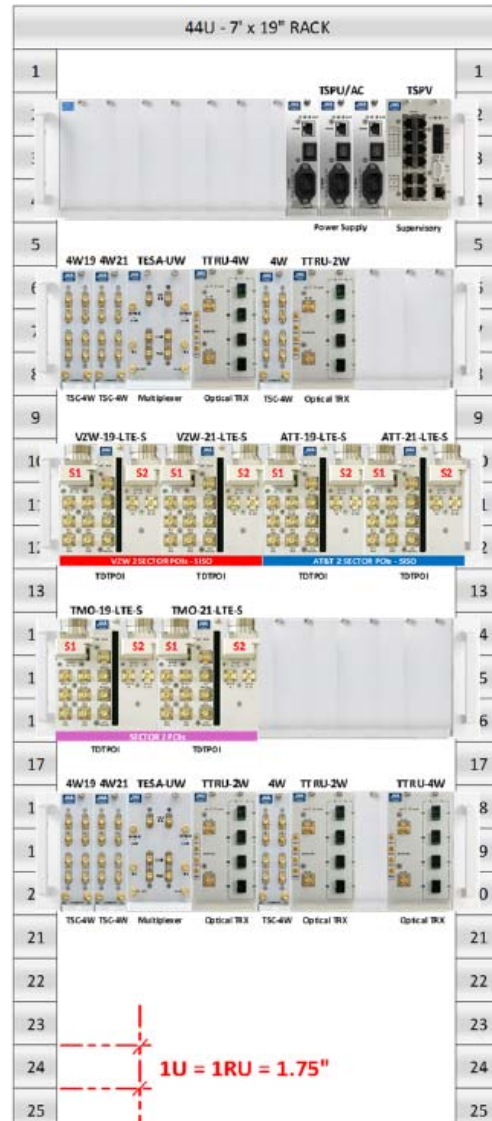

SECTOR 1

SECTOR 2

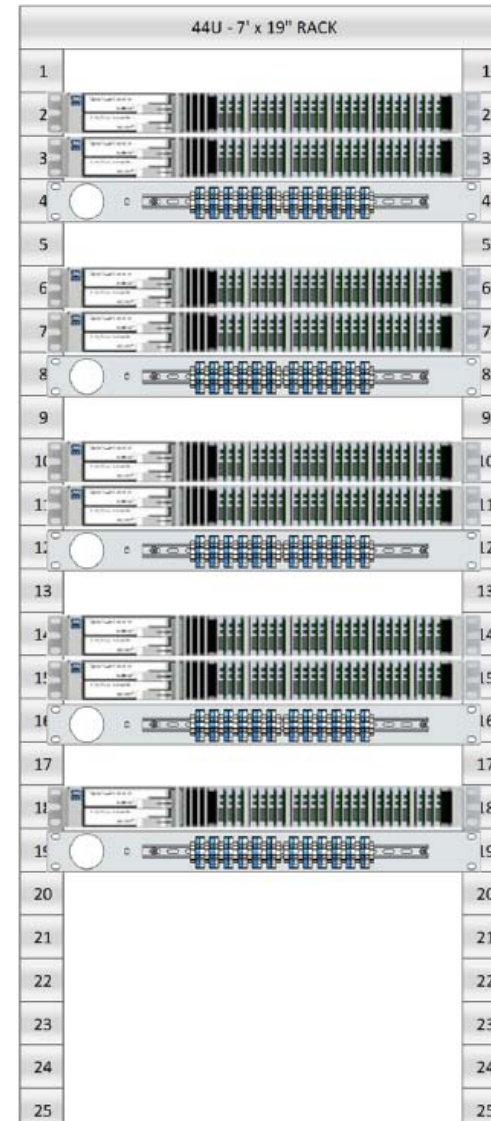

FD ET-BC-1800 + (1) FPC-500 = powering (2) 2B-RemoteUnits

FD ET-BC-1800 + (1) FPC-500 = powering (2) 2B-RemoteUnits

FTB-6 - for wiring transition

Design: Piecing It All Together

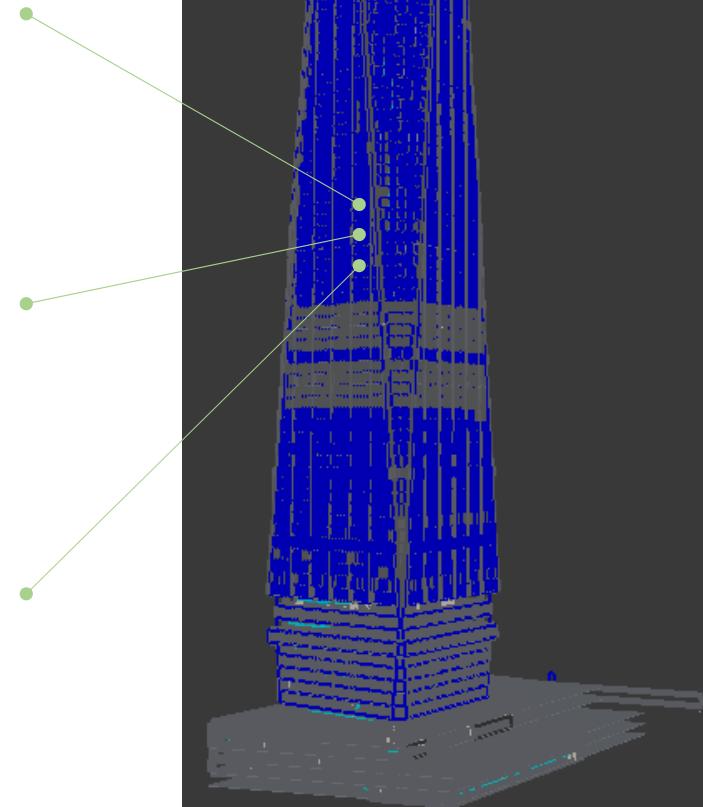
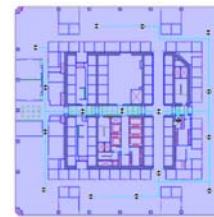
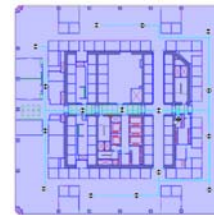
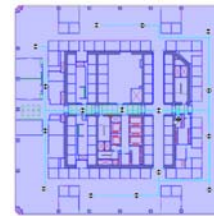
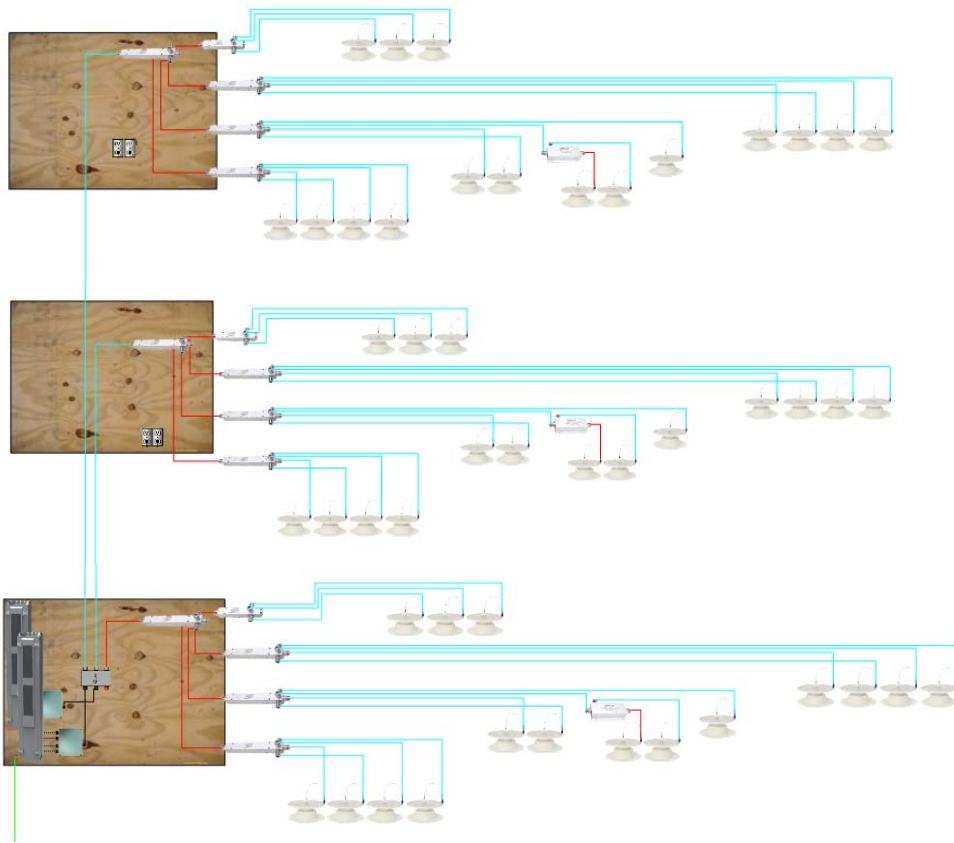

Design: Converged Networks

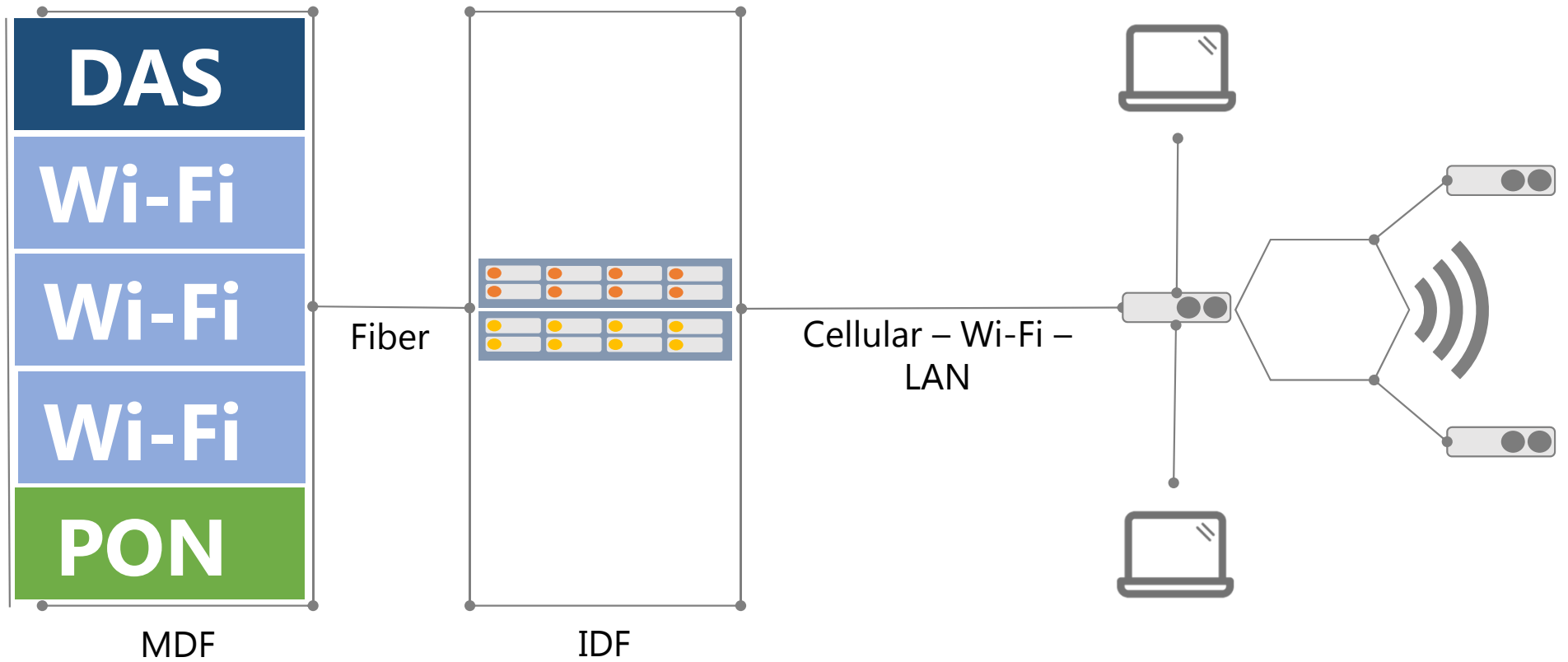

Design: The Value of Convergence



Traditional Implementation Strategy



Comprehensive Portfolio Strategy



Comprehensive Portfolio Strategy



DAS Installation

- IN-HOUSE TEAM OR DIRECT**
- MANAGEMENT**
- ON-SITE CONSTRUCTION**
- MANAGEMENT**
- PROFESSIONALISM**
- DETAILED DOCUMENTATION FOR**
- EACH PROJECT**
- STRATEGIC INSTALLATION**
- APPROACH**
- SWEEP, PIM AND OTDR STANDARDS**



Installation Documentation

A) Sample Connection from 1900 POI (S1 and S2) to Respective Sector 1900 TSC-4W Combiners (Repeat Same Procedure For AWS)

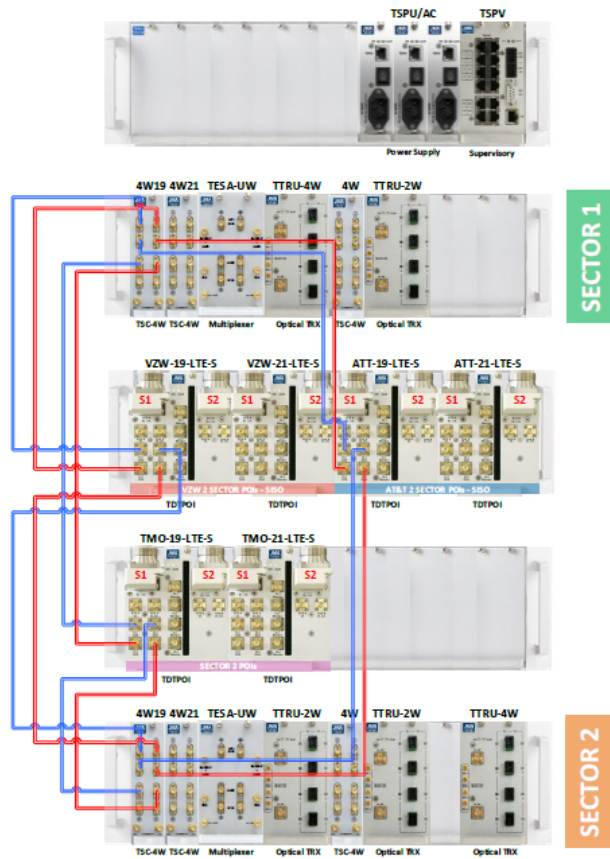

B) Interconnection from TSC-4W >> TESA-UW >> TSC-4W (Post TESA) >> TTRU/OTRX

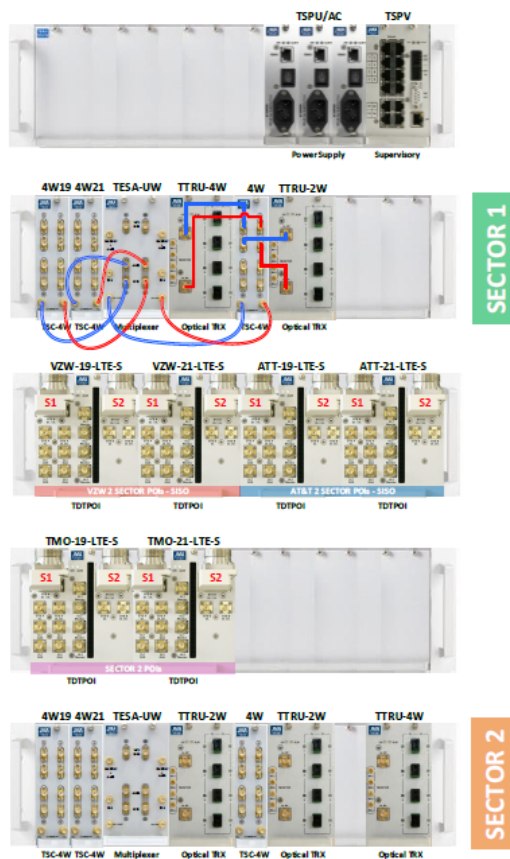

C) Power and Monitoring Connections (back of subrack)

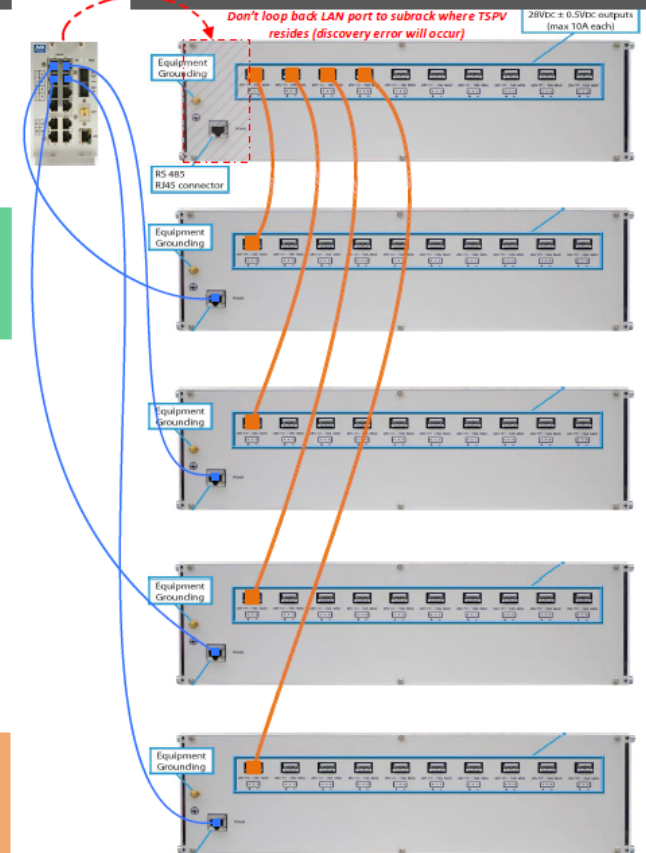

Installation Documentation

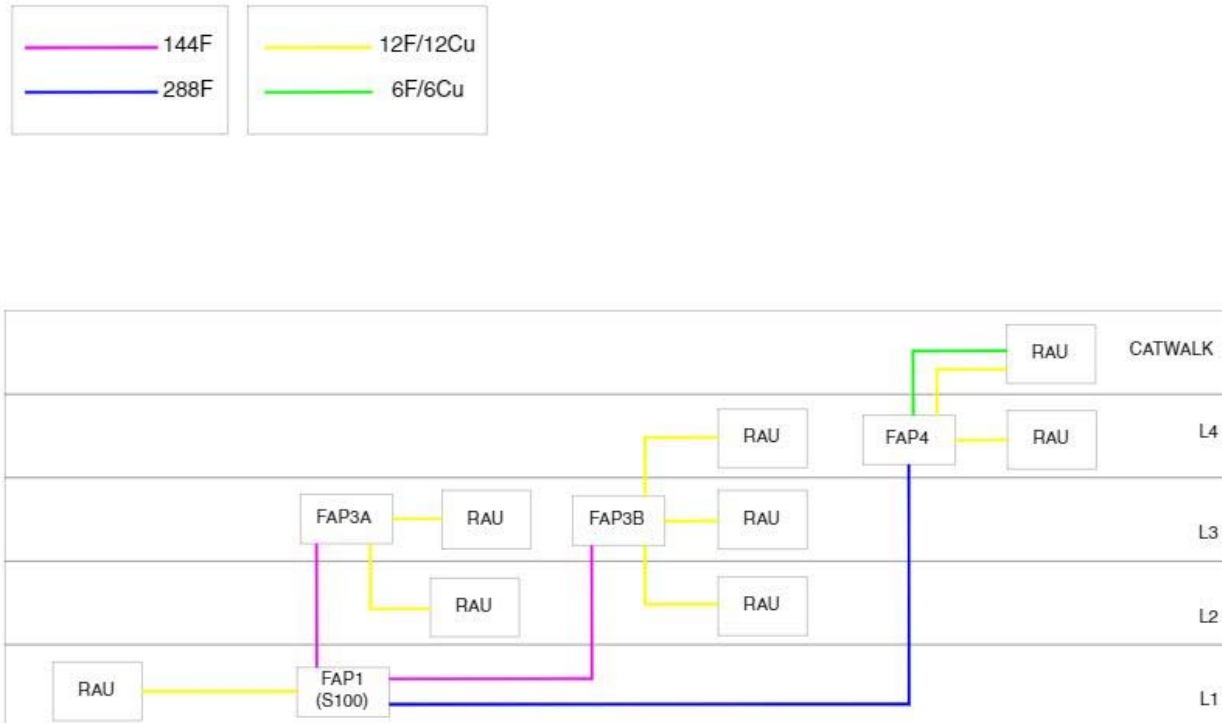

1 FIBER TRUNKING DIAGRAM



PROJECT INFORMATION
CARVER-HAWKEYE ARENA
 1 ELLIOTT DRIVE,
 IOWA CITY, IA 52242, UNITED STATES
 SITE: 001.FIBD

PROJECT NUMBER: CW-0004

ISSUE VERSION: XX-XX-XX

REV.	DATE	ISSUED FOR
0	02/24/16	FOR REVIEW PWS

PLANS PREPARED BY:



NOTES:



DRAWN BY: CRK APV

MS: SH

LICENSING:



SHEET TITLE:

FIBER TRUNKING DIAGRAM

SHEET NUMBER: REVISION:

F-1 0
REV.

Installation Components



BASE STATIONS

Head-end radio equipment, provided by the wireless carriers, that provides the RF signal source to drive the DAS



FIBER HEAD-END

Converts the RF signal to RF-over-fiber (RFoF), then transmits the signal via single-mode fiber-optic cable to the fiber remote unit



MULTI-BAND REMOTE UNIT

Converts the RFoF transmission back to an RF signal, which is then transmitted down coax cable to the coverage antenna



FIBER OPTIC CABLE

Transports the converted RF signals from the head-end equipment to the remote units



PLENUM CABLE

Transports the RF signals from the fiber remote unit—to the coverage antenna



SPLITTER

Splits the RF signals, which is then delivered to multiple inputs/elements



COVERAGE ANTENNAS

emits multi-band RF signals to the coverage area



Passive Components

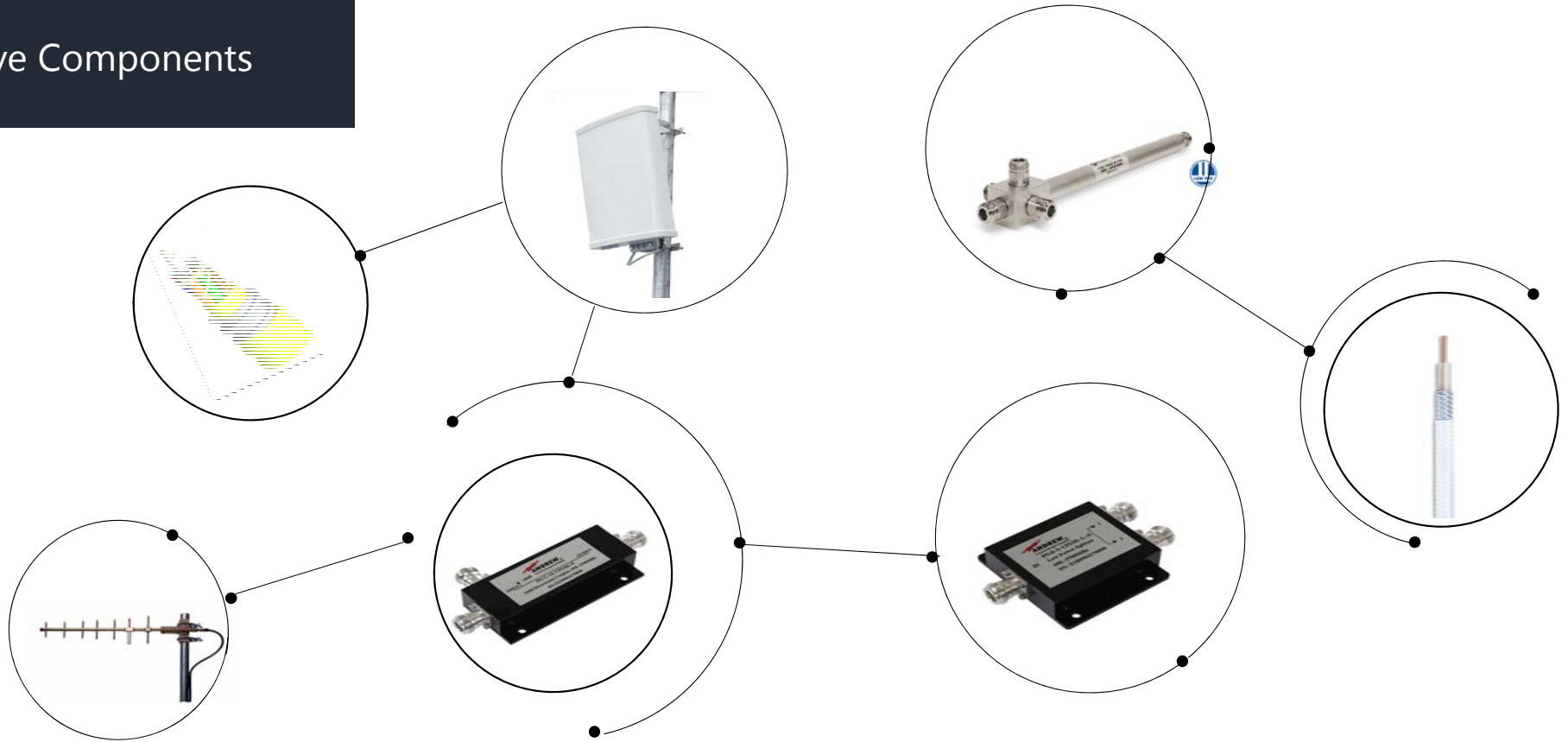

2018 BICSI Fall Conference & Exhibition



Active Components



Sample Remote Photos



Sample Remote Photos



Sample Antenna Photos



Sample Antenna Photos



Sample Antenna Photos

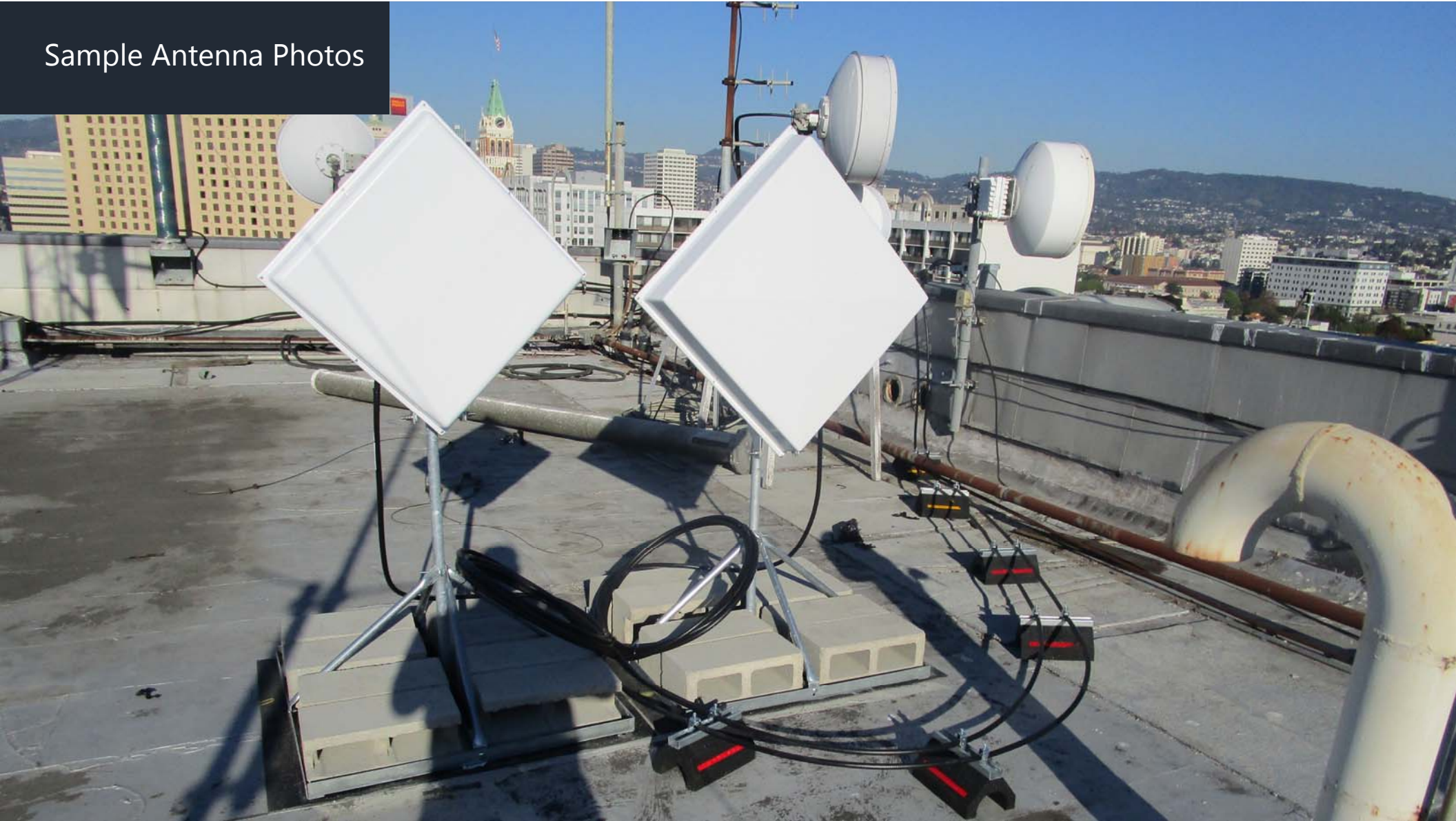

Aesthetics

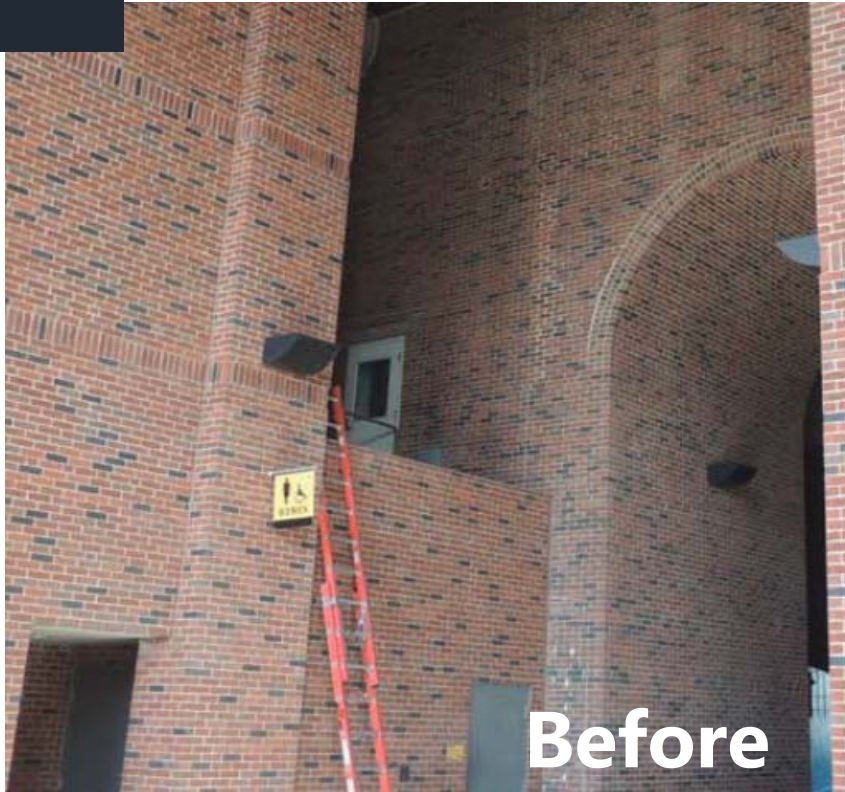

Aesthetics

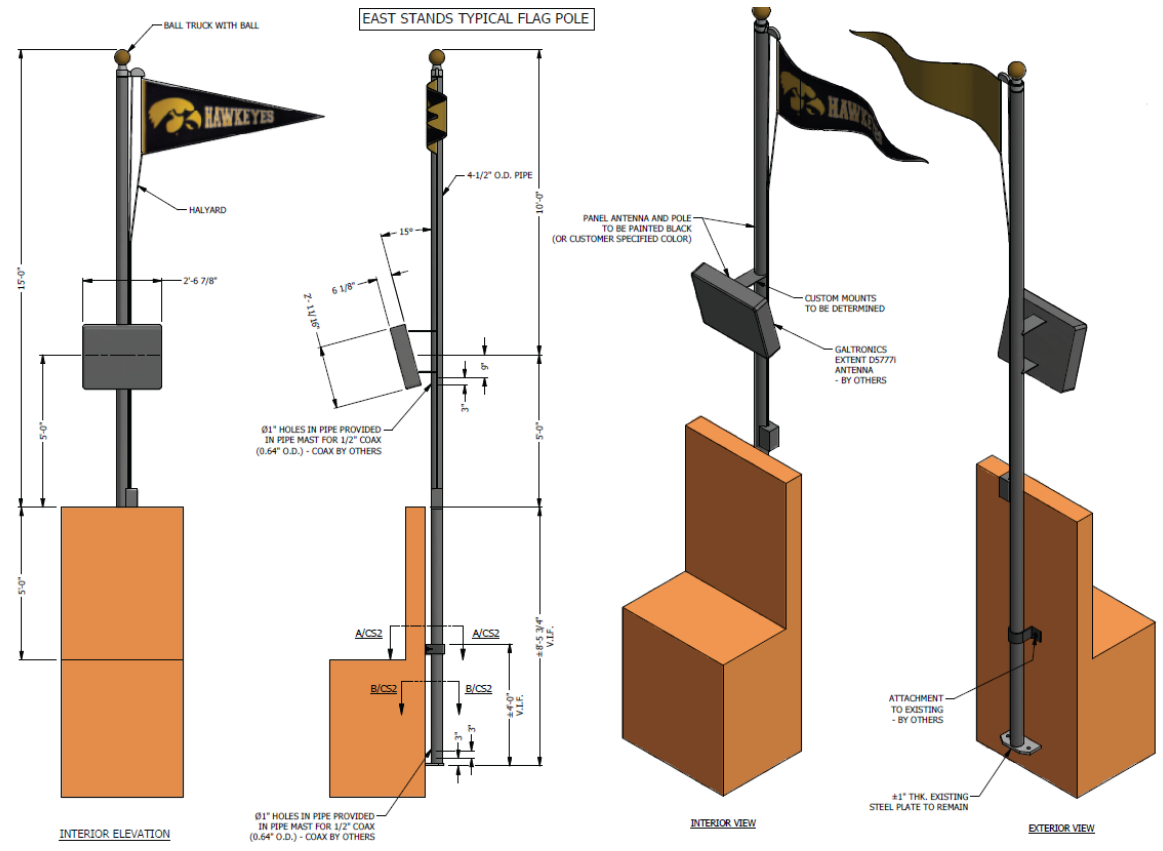



Commissioning is generally defined as the industry approved process and methodology of systematically verifying that the:

- System was installed correctly according to the design
- Active and passive components are functioning according to factory specification
- Link budget and associated DAS power metric performance matches the design specifications
- Intended carrier signals are integrated onto the DAS according to design and are done so within optimum equipment parameters
- Intended carrier signals are optimized to the systems optimum performance metrics, as determined by the design



Tools for Success

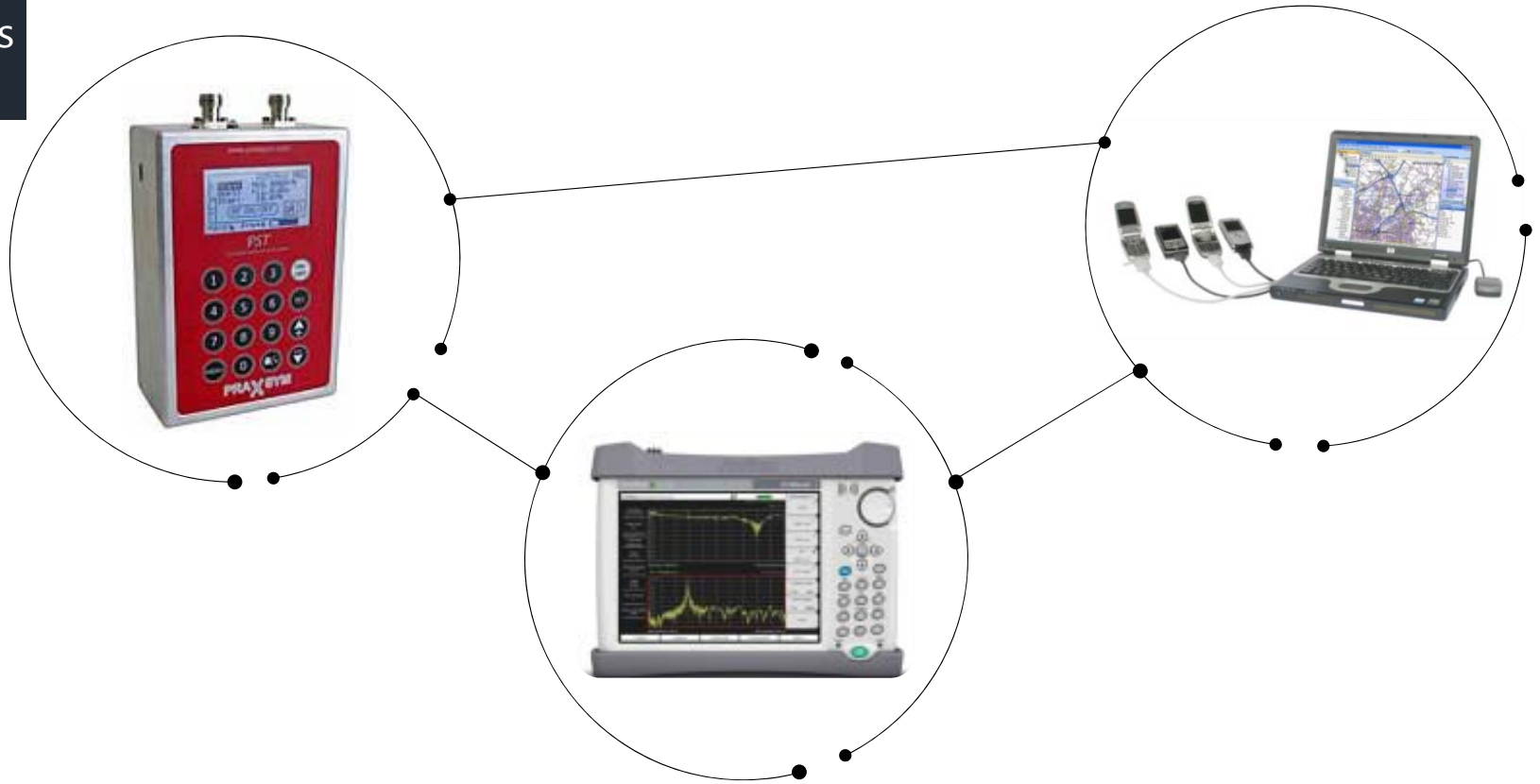

2018 BICSI Fall Conference & Exhibition



Data Processing

SWEEPS –
RL/DTF

PIM

FIBER

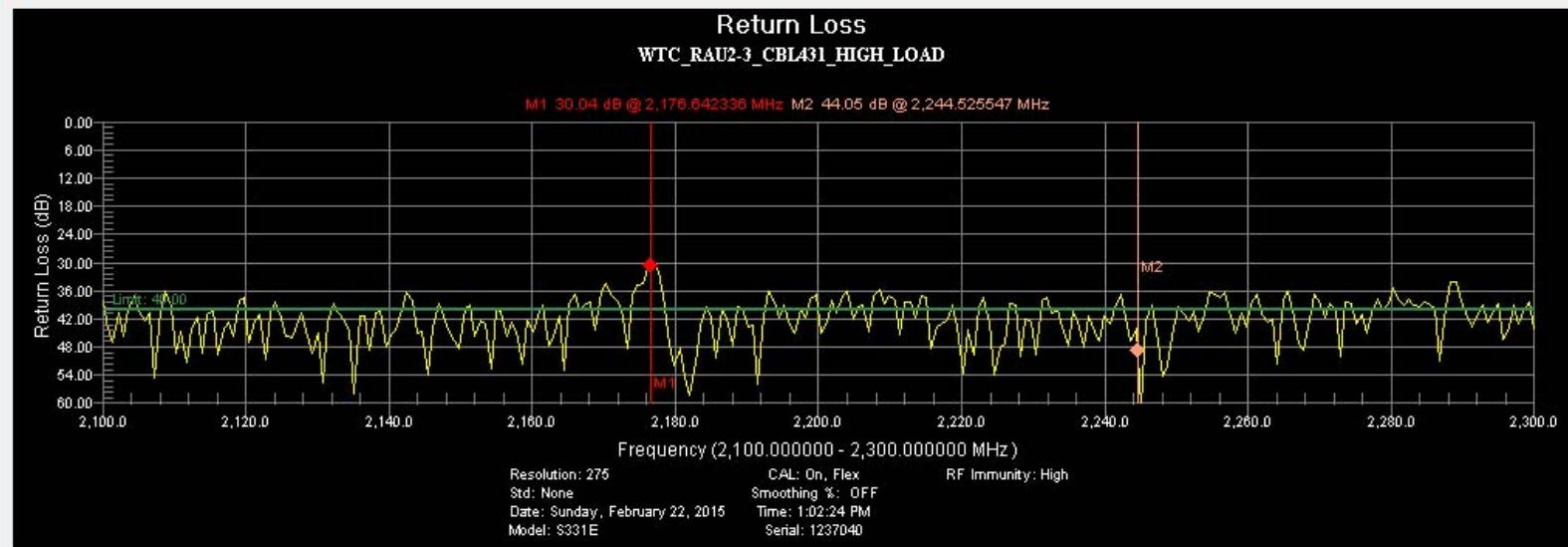
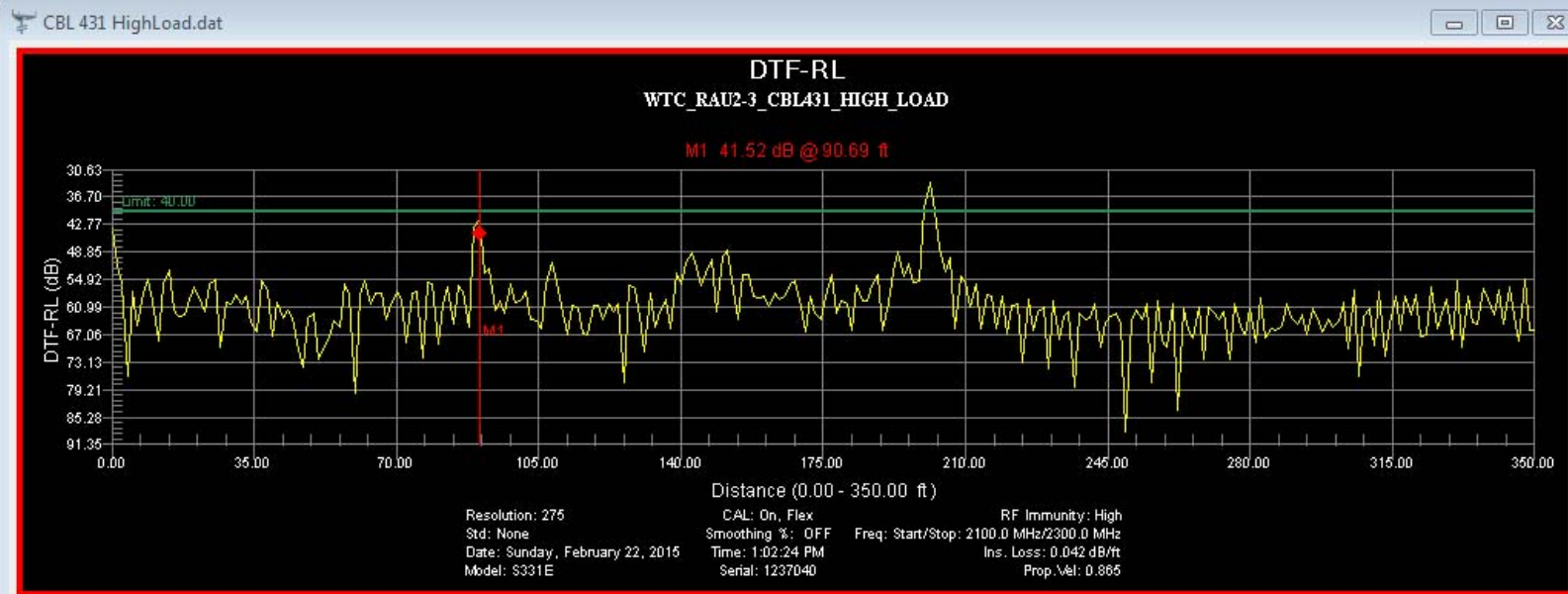

What is PIM?



PIM Passive Intermodulation exists when two or more signals are present in a passive device that exhibits nonlinear response



Commissioning Process

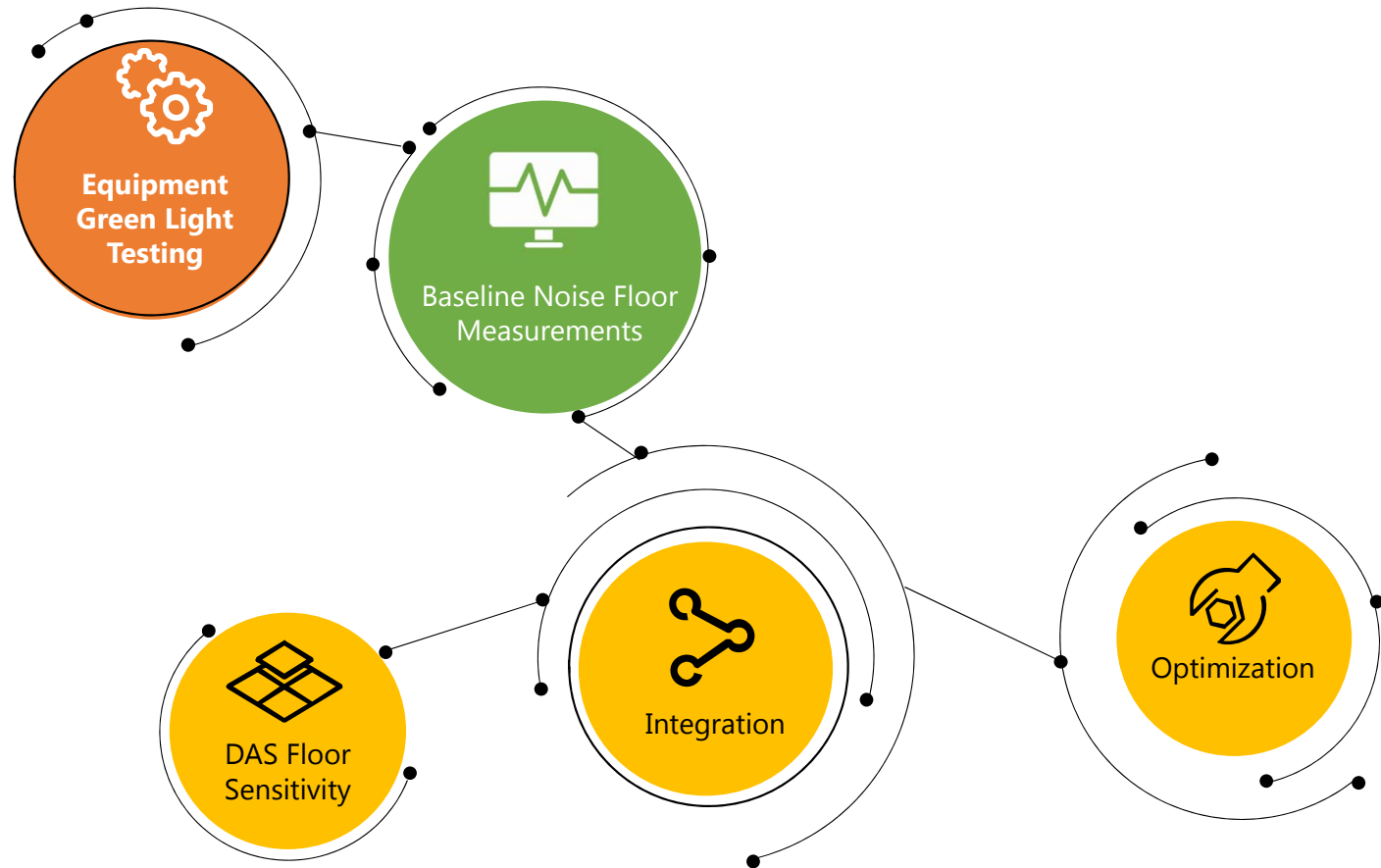

LET'S TALK ABOUT THE HEADEND (MDF).

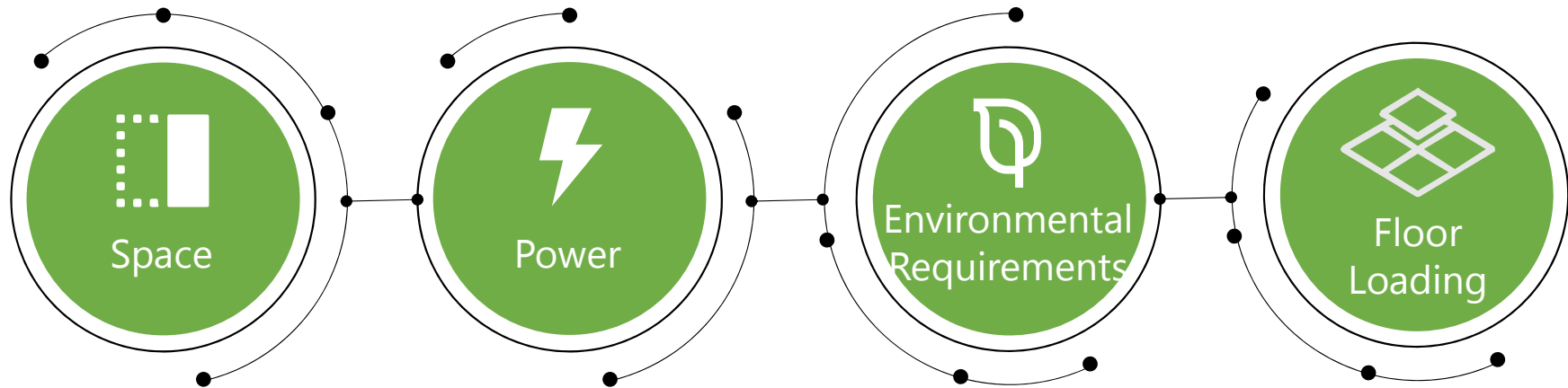

Head End Room: Requirements

SPACE FOR WIRELESS CARRIER BASE TRANSCIVER STATIONS (BTS) – SINGLE SECTOR

- 200 square feet per wireless carrier
- 800 to 1,000 square feet to accommodate all carriers
- Typically utilize existing MDF, but rooms can be retrofit to accommodate head end equipment

POWER REQUIREMENTS FOR THE HEAD-END ROOM

- 100 Amps 208 VAC three phase per carrier

ENVIRONMENTAL REQUIREMENTS FOR THE HEAD-END

- 2 tons HVAC per wireless carrier

Floor Loading

- 125 PSF for BTS equipment

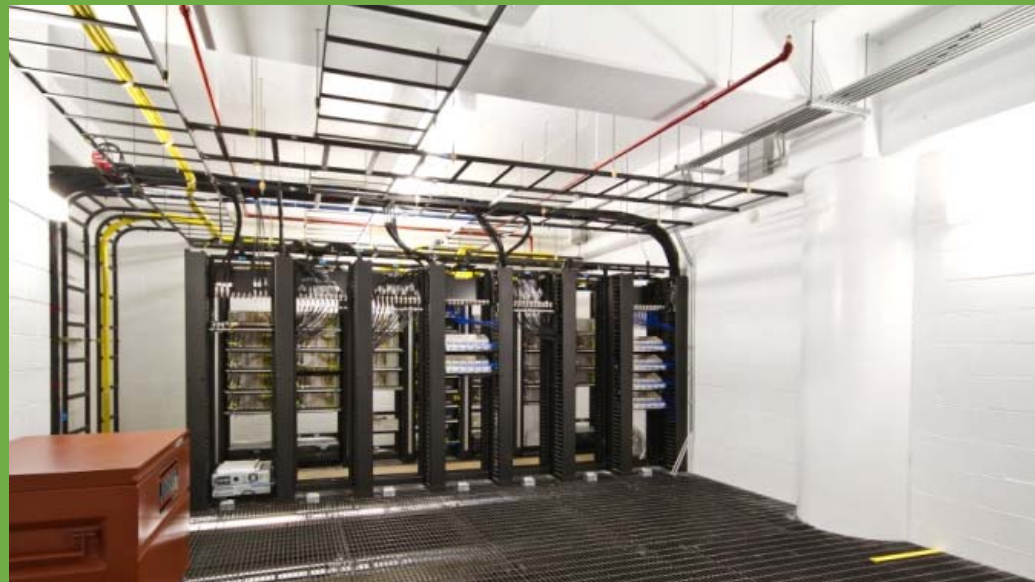

Head End Room: A&E Drawings

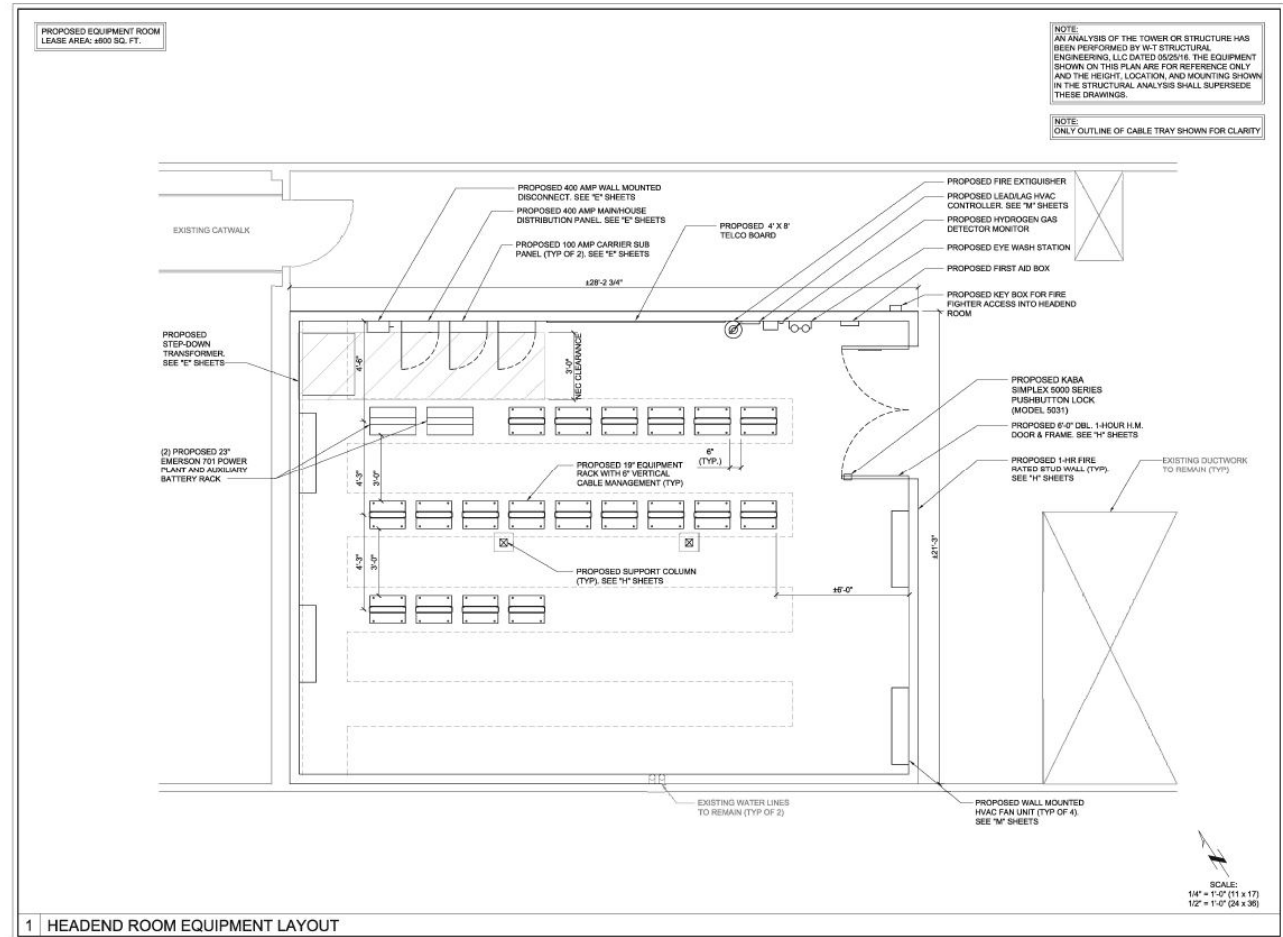

SAN DIEGO
CONNECTION PARTNER
111 W. HARBOR DRIVE
SAN DIEGO, CA 92101

SmartCity.

Connectivity:
Wireless Solutions
2707 MAIN STREET, SUITE 1
DULUTH, GA 30096

PLANS PREPARED BY:
W-T
W-T COMMUNICATION
DESIGN GROUP, LLC.
WIRELESS INFRASTRUCTURE
3805 S. BURNETT BLVD
PH: (248) 343-0233 FAX: (248) 343-0444
WWW.WTDESIGN.COM

W-T PROJECT NUMBER		T1605415
B/WAVE VERSION		
REV. DATE ISSUED FOR		
2	01/21/16	75% DRAWING PWS
3	02/09/16	FINALS PWS
4	02/17/16	PER COMMENTS BML
5	03/17/16	FOR PERMIT DVL
6	05/12/16	CITY COMMENTS BML
7	06/06/16	CITY COMMENTS DVL
DRAWN BY: PHIL SPICER		CHK: LAF CBW
LICENSEURE:		



SHEET TITLE:
HEADEND ROOM
EQUIPMENT LAYOUT
SOUTHWEST CORNER MECH. LVL.
SHEET NUMBER: **A-2** REVISION: **6**
REV

Head End Room: Photos

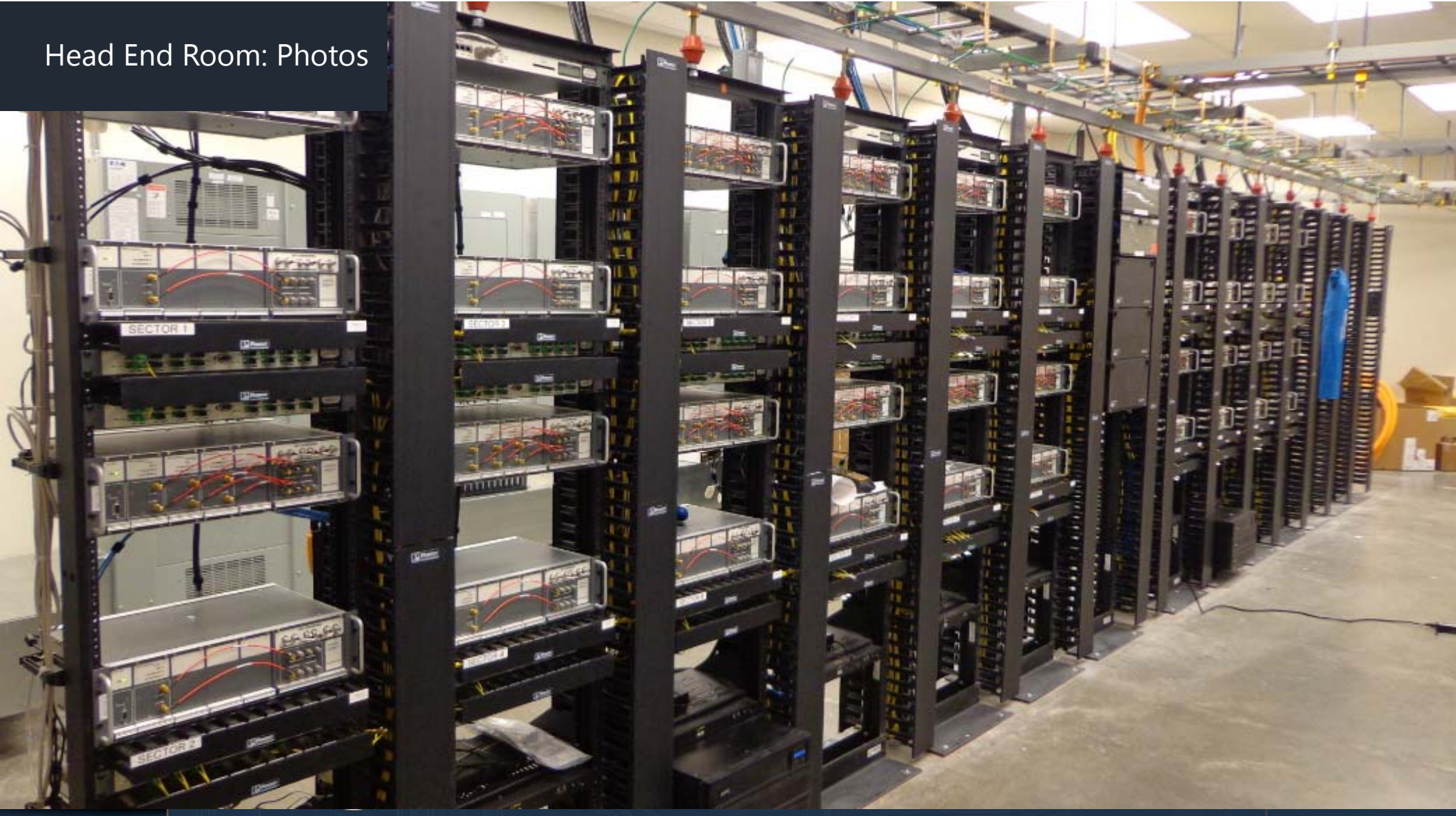

Head End Room: Carrier Equipment

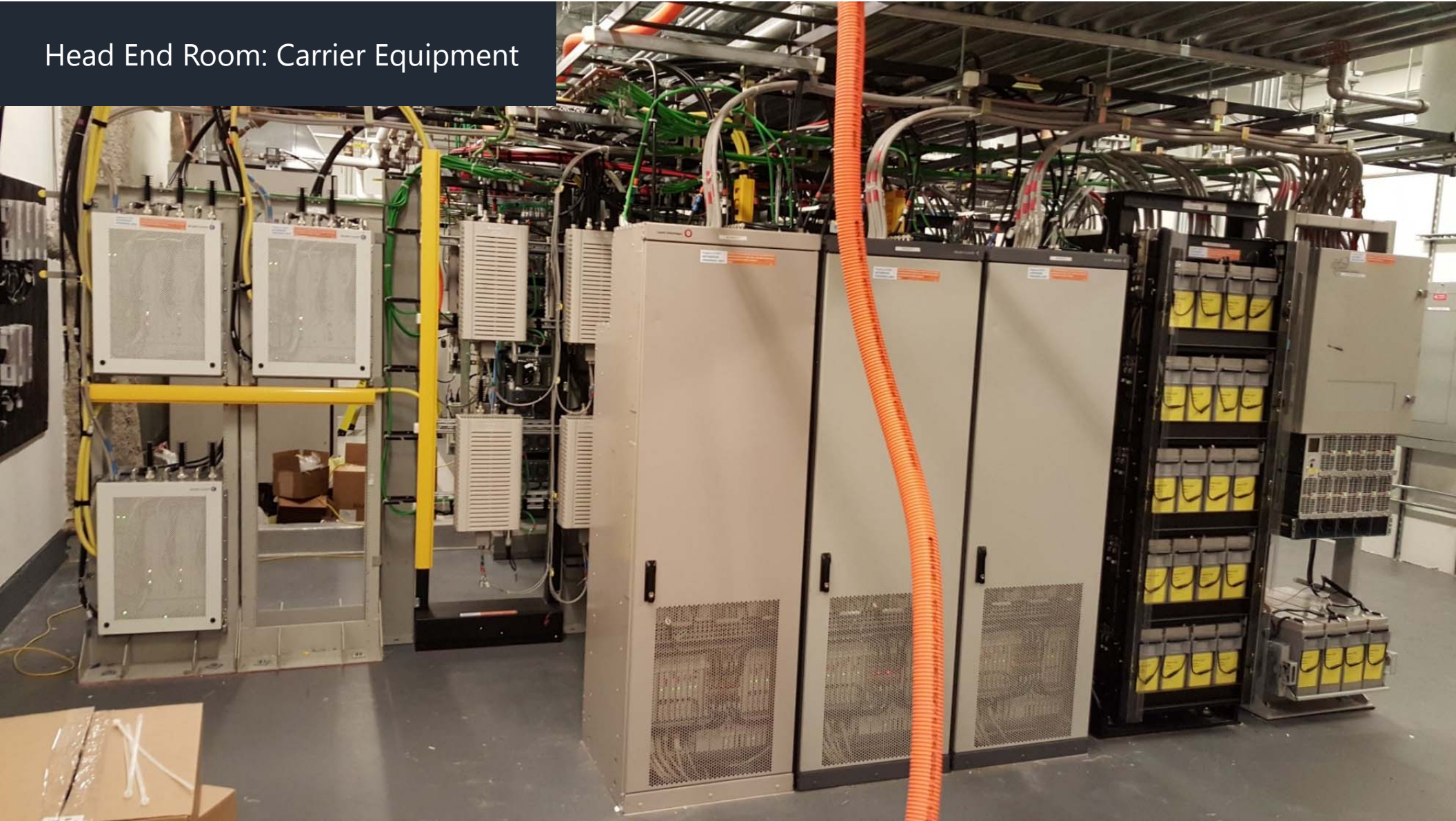

Monitoring and Maintenance

1 System Monitoring

2 Remote Diagnostics

3 Response & Repair

4 Preventive Maintenance



ConnectProtect

Complex systems require maintenance and preventative checkups to ensure longevity and optimal functionality.



2016 BICSI Fall Conference & Exhibition

Bicsi

Carriers & Case Studies



2018 BICSI Fall Conference & Exhibition



Bicsi

Ownership Models

Carrier

100% FUNDED AND OPERATED BY
Carrier

Typically single carrier

**Carriers may form
consortium**

**Neutral-host model
seldom materializes**

Neutral Host

100% FUNDED AND OPERATED BY
Independent third party
(i.e., tower company)

**Owner leases space back
to the carriers**

Neutral-host

**Carrier participation is
affected by cost model**

Enterprise

OWNED AND CONTROLLED BY
Enterprise

**Deployed and operated
by DAS integrator**

**Enterprise can operate as
neutral host provider**

**Multi-carrier funding
available**

Ownership Models

Carrier

PROS

Free is good

No maintenance or operational issues

Coverage-issue solved for those with that specific carrier

CONS

Very challenging for other carriers to join the system

Pricing barriers

Technical barriers

Neutral Host

PROS

Free is good

No maintenance or operational issues

Neutral means that any/ all carriers can join system

Possible revenue share

CONS

'Anchor carrier' model puts unfair burden on 1st carrier to join- delays process of implementation

Heavy fee/ finance/ mark-up on top of the system costs can make deal unattractive to carriers

Customer cannot touch system- unable to control upgrades/ enhancements/ related fiber infrastructure

Enterprise

PROS

Neutral system that any/ all carriers can join

Customer owns and control technology and infrastructure, in same way they do with structured cabling, network equipment, security, A-V, etc.

Leverage of system and infrastructure (fiber) for Wi-Fi

When structured correctly- system can be funded by carriers

CONS

Potential gaps between cost of system and funding by carriers

FCC released a new order for use of Enterprise DAS amplifiers:

FEBRUARY 20TH, 2013, FCC REPORT AND ORDER 13-21

Maintains that signal boosters require an FCC license or express licensee consent to install in commercial and industrial space.

The authorization process ensures that devices are operated only by licensees or with licensee consent and are adequately labeled to avoid misuse by consumers.



Wireless carrier coordination is **critical** to the success of any DAS project

CarrierConnect™

Wireless Carrier Coordination Methodology

PHASE 1

INITIATION

- Ecosystem Summary
- Carrier Engagement
- Carrier Registration
- RF Source Qualifying

PHASE 2

FUNDING

- Business Case Development
- Carrier Financial Analysis
- Funding Decision

PHASE 3

DESIGN

- Design Review
- Design Acceptance
- RF Source Specification

PHASE 4

REGULATORY

- Submittals
- Review
- Acceptance

PHASE 5

AUTHORIZATION

- Agreement Development
- Agreement review
- Agreement Execution

PHASE 6

Integration

- RF Source Installation
- RF Source Commissioning
- RF Source testing

KINNICK STADIUM

University of Iowa

CUSTOMER CHALLENGE:

- › Historic Kinnick Stadium of the University of Iowa was challenged to provide reliable wireless and data throughput speeds to fans during events.
- › Strict aesthetic requirements coupled with the need for ubiquitous, robust coverage to meet the 70,000 maximum capacity requirements for multiple carriers.

CONNECTIVITY'S SOLUTION:

- › Designed a 23 zone, neutral-host, 'fiber to the edge' Corning ONE DAS for the university.
- › DAS designed for dominance for all wireless carriers, supporting the technology and frequency bands owned in the market today with infrastructure to allow for future upgrades.

RESULT:

- › Installed and concealed 180 antennas, 360 remotes, and 58,000 ft. of fiber/composite cable. Allowing for excellent coverage while adhering to uncompromising aesthetic requirements.
- › DAS network provides ubiquitous coverage to fans inside the facility - servicing a total of 700,000 square feet.



HAWKEYE – CARVER ARENA

University of Iowa

CUSTOMER CHALLENGE:

- › Historic Carver-Hawkeye Arena of the University of Iowa was challenged to provide reliable wireless and data throughput speeds to fans during events.
- › Strict aesthetic requirements coupled with the need for ubiquitous, robust coverage to meet the 16,000 maximum capacity requirements for multiple carriers.

CONNECTIVITY'S SOLUTION:

- › Designed a 7 zone, neutral-host, 'fiber to the edge' Corning ONE DAS for the university.
- › DAS designed for dominance for all wireless carriers, supporting the technology and frequency bands owned in the market today with infrastructure to allow for future upgrades.

RESULT:

- › Installed and concealed 84 antennas, 168 remotes, and 29,000 ft. of fiber/composite cable. Allowing for excellent coverage while adhering to uncompromising aesthetic requirements.
- › DAS network provides ubiquitous coverage to fans inside the facility - servicing a total of 500,000 square feet.



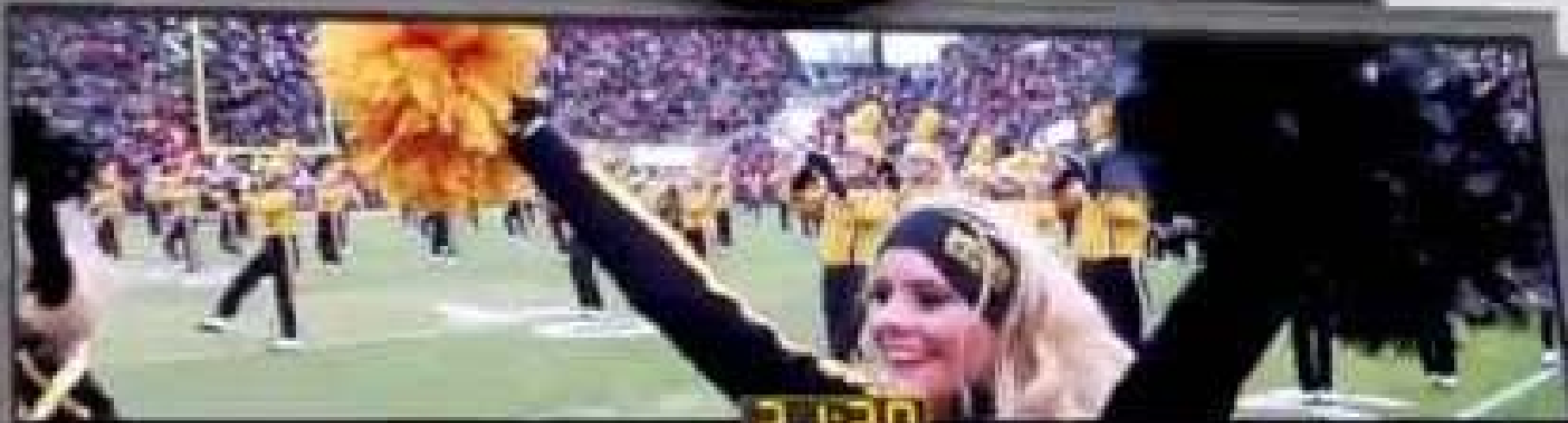

2 1:20

25

25

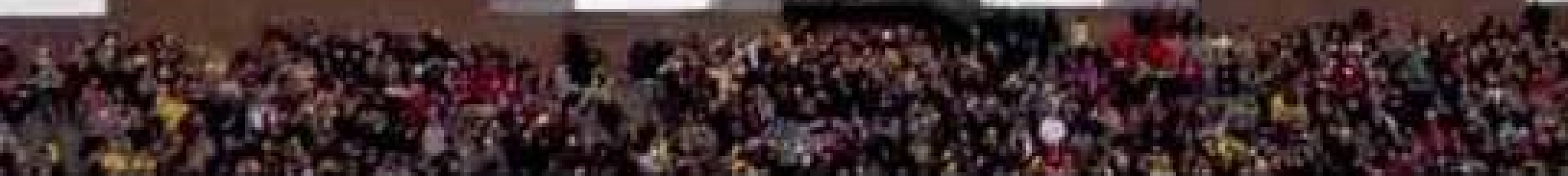

Questions?

- Thank you -

Scott Rahim

National Solutions Engineer
404-348-6221
srahim@connectivitywireless.com

Mark Niehus, RCDD

Director of Strategic Accounts
206-380-0082
mniehus@connectivitywireless.com



2018 BICSI Fall Conference & Exhibition



Bicsi