

Interpreting the NEC for Structured Cabling

By Tim Kuhlman, PE RCDD CDT

TEECOM

Schedule

- 1:00pm to 2:45pm
- 2:45pm – **15 minute break**
- 3:00pm to 4:15pm
- 4:15pm Q&A and wrap up
- 4:30pm – **The End**

Purpose of this Course

- Detail Review of the NEC® as it Applies to Telecom Design
 - Overview of the NEC Structure
 - Interpreting Technique
 - Understanding Article 800
 - Article 725 Defined
 - Classification of Cables
- Subjects:
 - Plenum Spaces
 - Securing & Supporting Conductors
 - Separation from other Conductors
 - Article 645 Information Technology Equipment
 - Fiber Optic Cables
 - Raceway
 - Cable Tray
 - Unlisted Cables
 - Circuit Protection

Purpose of this Course

- Not Covered in This Seminar
 - Audio Cables
 - Radio
 - Health Care Specific Requirements
 - Residential
- Intended Audience
 - Targeting Commercial and Industrial Environments



True or False Panel of Experts

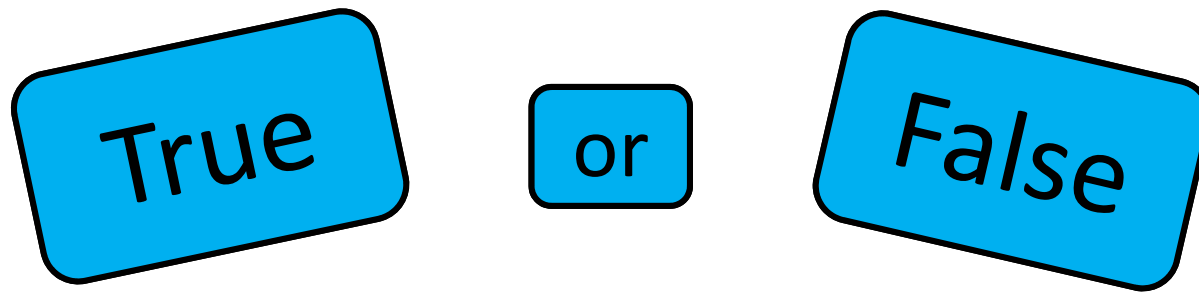

- I would like 5 volunteers that consider themselves experts in the National Electrical Code.
- Throughout the seminar we will be asking for our Panels of Experts opinion on whether a statement made by the Presenter is True or False.

True or False

Sample question for our Panel of Experts:

True or False: Cable Trays, when used in electrical installations, are limited to supporting wires and cables.



True or False

Sample question for our Panel of Experts:

True or False: Cable Trays, when used in electrical installations, are limited to supporting wires and cables. Answer: **False**

392.2 Definitions

Cable Tray Systems. *A unit or assembly of units or sections and associated fittings forming a structural system used to securely fasten or support cables and raceways.*



References

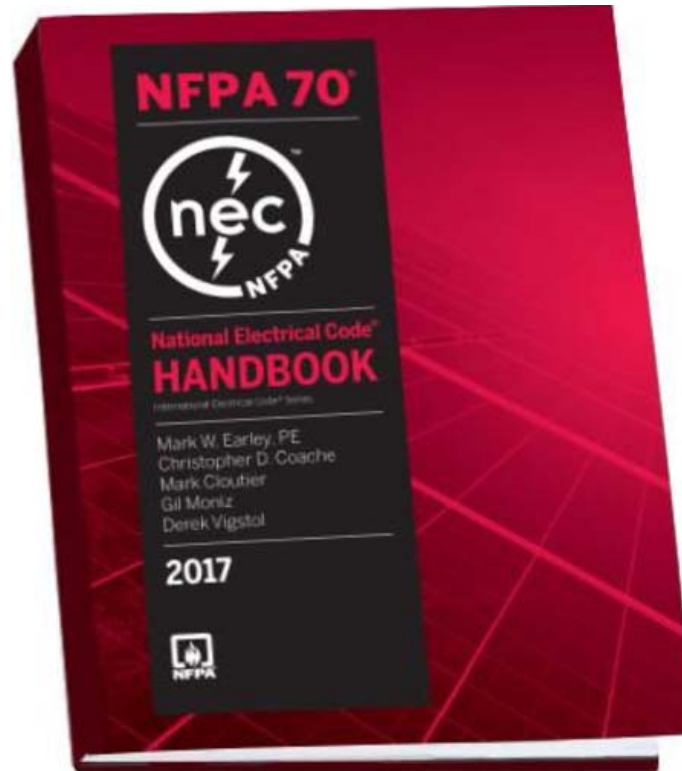
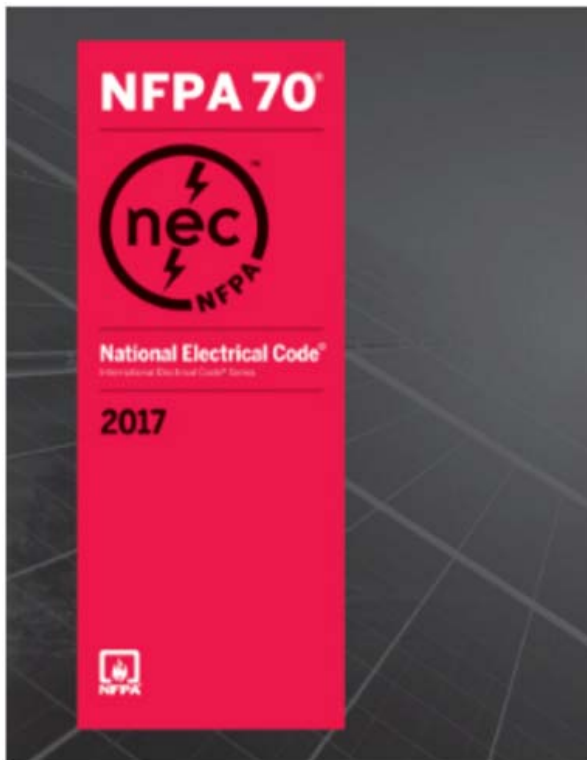

References

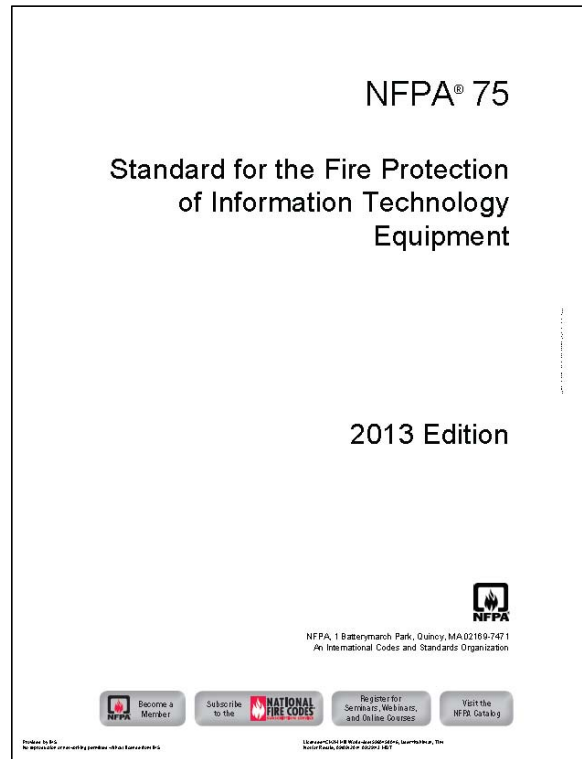

NFPA 2017 edition has been published but the 2017 edition of the NEC references the 2013 edition.

Color Code for this Presentation

- Items in a box are a direct quote from the NEC.
- Items with a Red Underline are editorial highlights.
- Items in black presentation text are partial NEC quotes, editorial notes, comments or conclusions.
- Items from the code that are changes in the 2017 edition appear in underline and sometimes ~~text-strikeout~~.

Code Interpretations

- Through the course of this seminar we will be making Code interpretations.
 - The interpretations in this seminar may differ from
 - your interpretation
 - the interpretation from your local inspector
 - Interpretations will be made based on:
 - Text, taken in context, and definitions of the NEC
 - Text from supporting NFPA documents
 - The NEC Handbook; considered as an expert opinion
 - Other documents, such as UL Standards, referenced by the NEC in informational notes.

NEC® Structure

- The National Electrical Code is not written for the casual reader. To properly interpret the Code you must know:
 - Who is it written for
 - The NEC organization
 - The NEC definitions
 - How to apply this to Telecommunications



NEC® Authoring

- NFPA 70® aka the NEC®
 - Authored by the NFPA using a consensus standards process.
 - Volunteers from the industry serve on different Article Committees to consider revisions and updates to the Code.
 - Code Panel 16 includes Articles 770 & 800, 810, 820, 830 and 840
 - Representing BICSI – Robert Jensen, dbi, TX
 - Code Panel 3 includes Articles 300 & 725
 - Representing BICSI – Ray Keden, Pentair-ERICO, CA
 - Representing BICSI – Richard Anderson, RTKL Assoc. VA (Alt to Ray Keden)
- There are many other volunteers.
- The make up of the Code panels help to ensure there isn't bias towards one interest, manufacturer, industry or representative.

Who is the NEC® Written For?

- Refer to Article 90 – Introduction
- 90.1 Purpose

(A) Practical Safeguarding. *The purpose of this Code is the practical safeguarding of persons and property from hazards arising from the use of electricity. This Code is not intended as a design specification or an instruction manual for untrained persons.*

- Note: The Code does not address system performance unless the performance of a system could compromise safeguarding.

Who is the NEC® Written For?

- Originally written at the request of underwriters (insurance companies)
- Article 90 Introduction
- 90.1 Purpose
 - Its intended audience are people that already have an understanding of electrical systems
 - It's not a training manual
 - It does not provide values for design performance



Who Enforces the NEC®?

- *History and Development of the NEC:*

This Code is purely advisory as far as the NFPA is concerned. It is made available for a wide variety of both public and private uses in the interest of life and property protection....

- 90.4 Enforcement

90.4 Enforcement. This Code is intended to be suitable for mandatory application by governmental bodies that exercise legal jurisdiction over electrical installations, including signaling and communications systems, and for use by insurance inspectors. The authority having jurisdiction for enforcement of the Code has the responsibility for making interpretations of the rules. for deciding on the approval of equipment and materials, and for granting the special permission contemplated in a number of the rules.

...

Enforcement

- Enforceable by the AHJ (Authority Having Jurisdiction).
- Interpreted by the AHJ through its enforcement.
- The interpretations of what you may have to apply may be different than what we discuss today.
- The AHJ may waive specific requirements.
- The Code may require new products or methods that may not yet be available. The AHJ can rule on using the previous edition of the Code.
- It is recommended to get any AHJ Code rulings or interpretations in writing.



What is Covered, What is Not?



- *90.2 Scope*

(A)Covered. *This Code covers the installation and removal of electrical conductors, equipment, and raceways; signaling and communication conductors, equipment, and raceways; and optical fiber cables and raceways for the following:*

- *(1) Public and private premises, buildings, structures, mobile homes, RV's...*
- *(2) Yards, Lots, carnivals....*
- *(3) Installation of conductors and equipment that connect to the supply of electricity.*

Question to the panel question: The NEC is intended to be used by your local telephone provider for their facilities?

What is Covered, What is Not?

- *90.2 Scope*

(B) Not Covered. *This Code does not cover the following:*

- (1) *Installations in ships, watercraft other than floating buildings, railway rolling stock, aircraft, or automotive vehicles other than mobile homes and recreational vehicles...*
- (2) *Installations underground in mines...*
- (3) *Installations of railways for generation, transformation, transmission, energy storage, or distribution of power used exclusively for operation of rolling stock...*

What is Covered, What is Not?

- *90.2 Scope*
 - (4) *Installations of communications equipment under the exclusive control of communications utilities located outdoors or in building spaces used exclusively for such installations.*
 - (5) *Installations under the exclusive control of an electric utility where such installations....*
- Informational note in this article helps to define a “utility”

Answer to the panel question: Is the NEC intended to be used by your local telephone company? False. Although Utility could adopt the Code, they may not be obligated to follow it accept when installing in a private building.

NEC® Organization

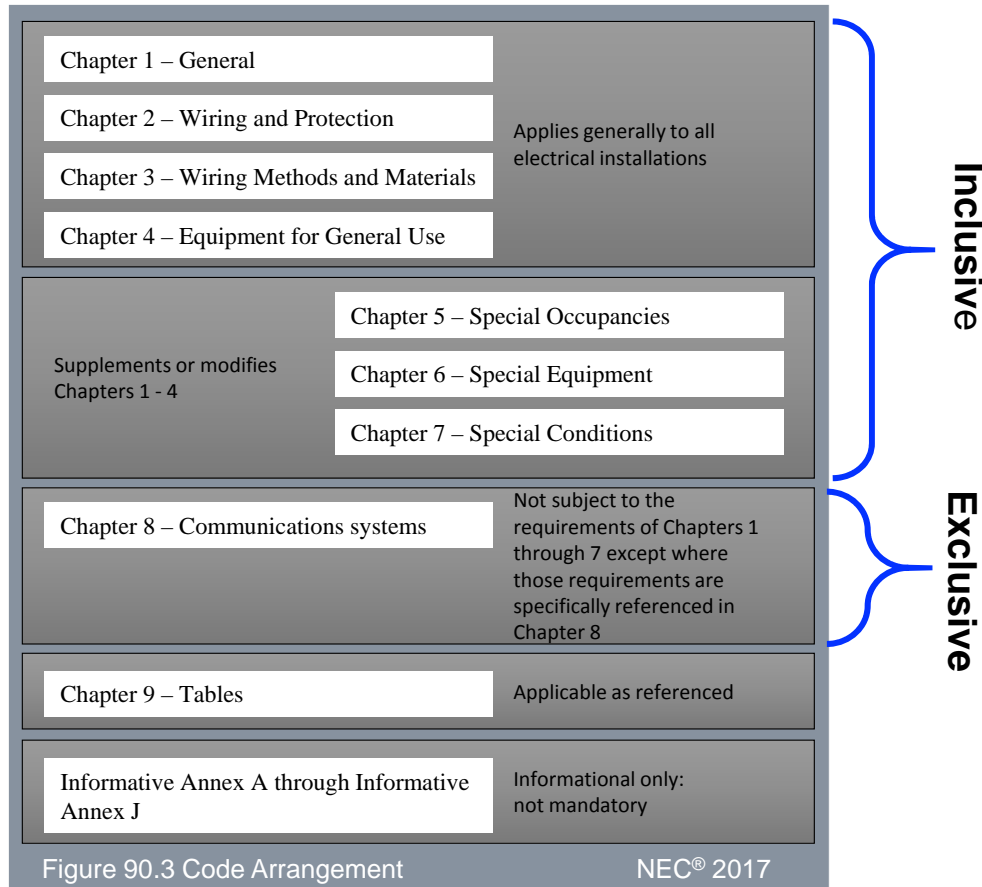

- 90.3 Code Arrangement
 - Chapters 1, 2, 3 & 4 generally apply unless amended by Chapters 5, 6 or 7.
 - Unless Chapter 8 references another section of the Code, other sections do not apply to a Chapter 8 item.

NEC® Organization

- Chapters 1, 2, 3 & 4 generally apply unless amended by Chapters 5, 6 or 7.
- For Example:
 - Article 725 - Class 1, Class 2, and Class 3 Remote-Control, Signaling, and Power Limited Circuits.

725.3 Other Articles. *Circuits and equipment shall comply with the articles or sections listed in 725.3(A) through (N). Only those sections of Article 300 referenced in this article shall apply to Class 1, Class 2, and Class 3 circuits.*

NEC® Definitions



- To properly interpret the code, it is necessary to understand the NEC's definitions to have the proper context of the rules.
- Article 100 has a list of definitions.
- Individual Articles will have additional definitions.
 - Article 800 is a standalone article but references Article 100 in 800.2. Therefore Article 100 applies. The terms defined in Article 90 Introductions also applies.

Question to the panel question: Are informational notes in the Code considered mandatory and enforceable parts of the Code? True or False

NEC® Definitions

For Example, Article 725:

- This section modifies Chapter 1 through 4 but does not modify the definitions of Article 100, therefore they apply.
- Article 725 has additional definitions.

Other Definitions

- Refer to words used in context by the NEC®
- Refer to the NEC® Handbook.
- Refer to other NFPA documents

NEC® Definitions

- Other Definitions

- 90.5 Mandatory Rules, Permissive Rules, and Explanatory Material

(C) Explanatory Material. Explanatory material, such as references to other standards, references to related sections of this *Code*, or information related to a *Code* rule, is included in this *Code* in the form of informational notes. Such notes are informational only and are not enforceable as the requirements of this Code.

...

- Definitions from the IEEE, TIA and BICSI may not apply to directly to an NEC® interpretation.

Answer to the panel question: Are informational notes in the Code considered mandatory and enforceable parts of the Code? False.

Interpreting Techniques

(C) Composite Cables. Cables constructed of individually listed Class 2, Class 3, and communications cables under a common jacket shall be permitted to be classified as communications cables. The fire resistance rating of the composite cable shall be determined by the performance of the composite cable.

In a typical office environment consisting of a group of computers in a local area network, data wiring is as prevalent as telephone wiring. A common way to minimize the amount of cabling is to run the telephone and data circuits in the same cable. Exhibit 725.4 illustrates such an arrangement. Section 725.139(D) requires that a communications cable be used for this purpose.

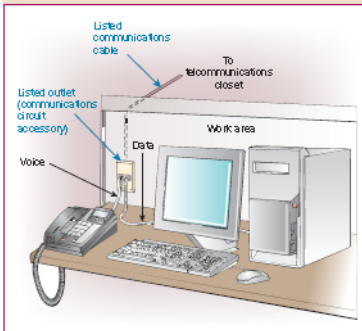

Exhibit 725.4 Telephone and data circuits in the same cable.

(E) Class 2 or Class 3 Cables with Other Circuit Cables. Jacketed cables of Class 2 or Class 3 circuits shall be permit-

System Circuits. Audio system circuits described in 640.9(C), and installed using Class 2 or Class 3 wiring methods in compliance with 725.133 and 725.154, shall not be permitted to be installed in the same cable or raceway with Class 2 or Class 3 conductors or cables.

725.141 Installation of Circuit Conductors Extending Beyond One Building

Where Class 2 or Class 3 circuit conductors extend beyond one building and are run so as to be subject to accidental contact with electric light or power conductors operating over 300 volts to ground, or are exposed to lightning on interbuilding circuits on the same premises, the requirements of the following shall also apply:

- (1) Sections 800.44, 800.50, 800.53, 800.93, 800.100, 800.170(A), and 800.170(B) for other than coaxial conductors
- (2) Sections 820.44, 820.93, and 820.100 for coaxial conductors

725.143 Support of Conductors

Class 2 or Class 3 circuit conductors shall not be strapped, taped, or attached by any means to the exterior of any conduit or other raceway as a means of support. These conductors shall be permitted to be installed as permitted by 300.11(B)(2).

See the commentary following 725.24 for more information on the support of conductors.

725.154 Applications of Listed Class 2, Class 3, and PLTC Cables

Class 2, Class 3, and PLTC cables shall comply with any of the requirements described in 725.154(A) through (H).

(A) Plenums. Cables installed in ducts, plenums, and other spaces used for environmental air shall be Type CL2P or

- Start with NEC® and definitions
- Use the NEC® Handbook as an expert opinion of the Code.
 - The editorial notes in the handbook are not the Code itself but provide insight to the meaning of the Code. It also provides illustrations that the NEC® does not.
- If you submit a technical request to the NFPA, you may get a direct response from a NEC® Handbook author.

Interpreting Techniques

- The Code is not written in a form that makes it the easiest to understand.
- It is not uncommon for the Code to write with run-on sentences.
- For Example:

90.2 Scope.

(A) Covered. *This Code covers the installation and removal of electrical conductors, equipment, and raceways; signaling and communication conductors, equipment, and raceways; and optical fiber cables and raceways for the following:*

Interpreting Techniques

- Article 90 Introduction

90.2 Scope.

(A) Covered. *This Code covers the installation and removal of electrical conductors, equipment, and raceways; signaling and communication conductors, equipment, and raceways; and optical fiber cables and raceways for the following:*

- Note the semicolons breaking up the list.
- Punctuation is important.

Let's eat grandma.
Let's eat, grandma.

Interpreting Techniques

- Article 90 Introduction
 - **90.2 Scope – (Rewritten with bullets instead of semicolons.)**
 - **(A) Covered.** *This Code covers the installation and removal of*
 - *Electrical conductors, equipment, and raceways;*
 - *Signaling and communication conductors, equipment, and raceways;*
and
 - *Optical fiber cables and raceways for the following:*

Interpretation Example

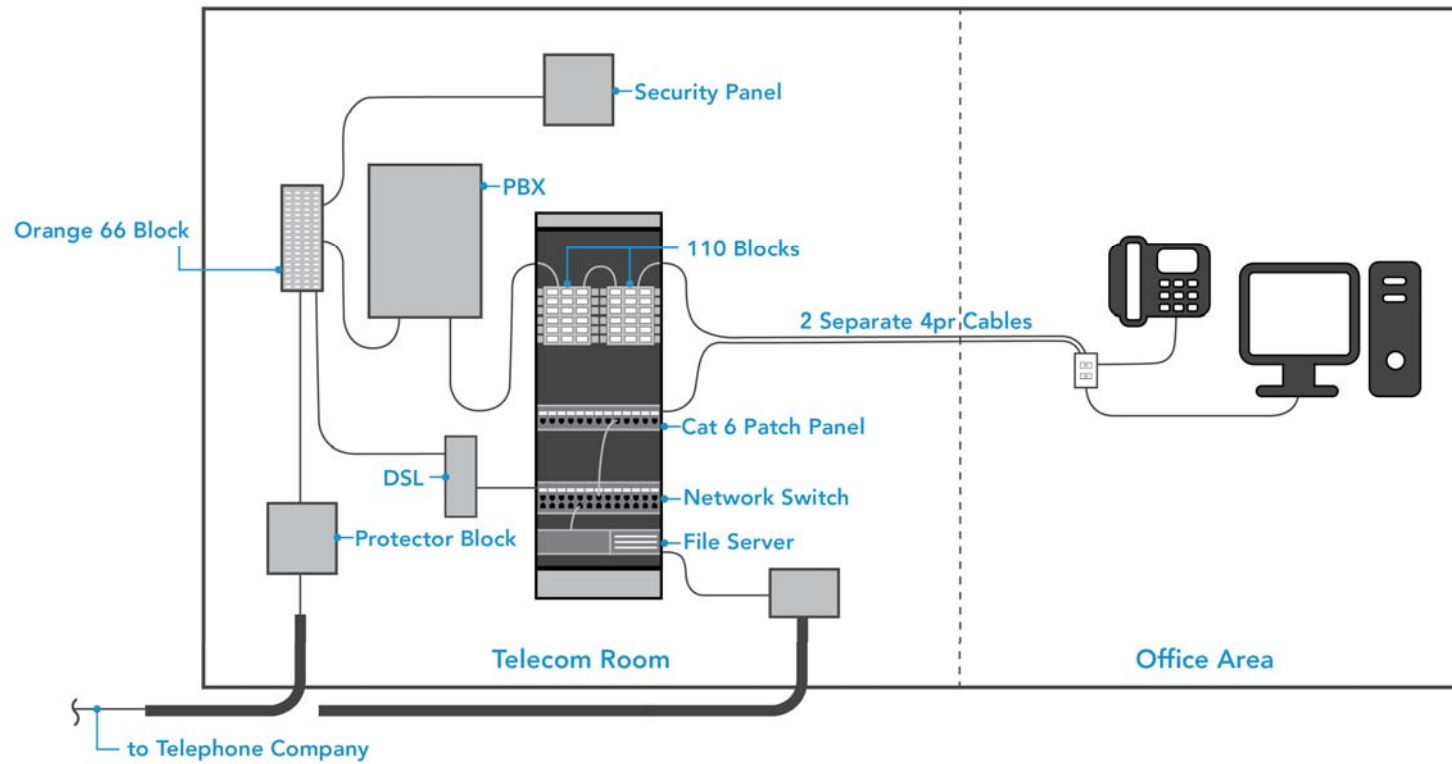

Interpretation Example

- In this example we will look at what is the actual scope of Article 800.
- Let's ask the question: Does Article 800 apply to the installation of a Category 6 cable from a network switch and PBX to a workstation outlet?

Interpretation Example

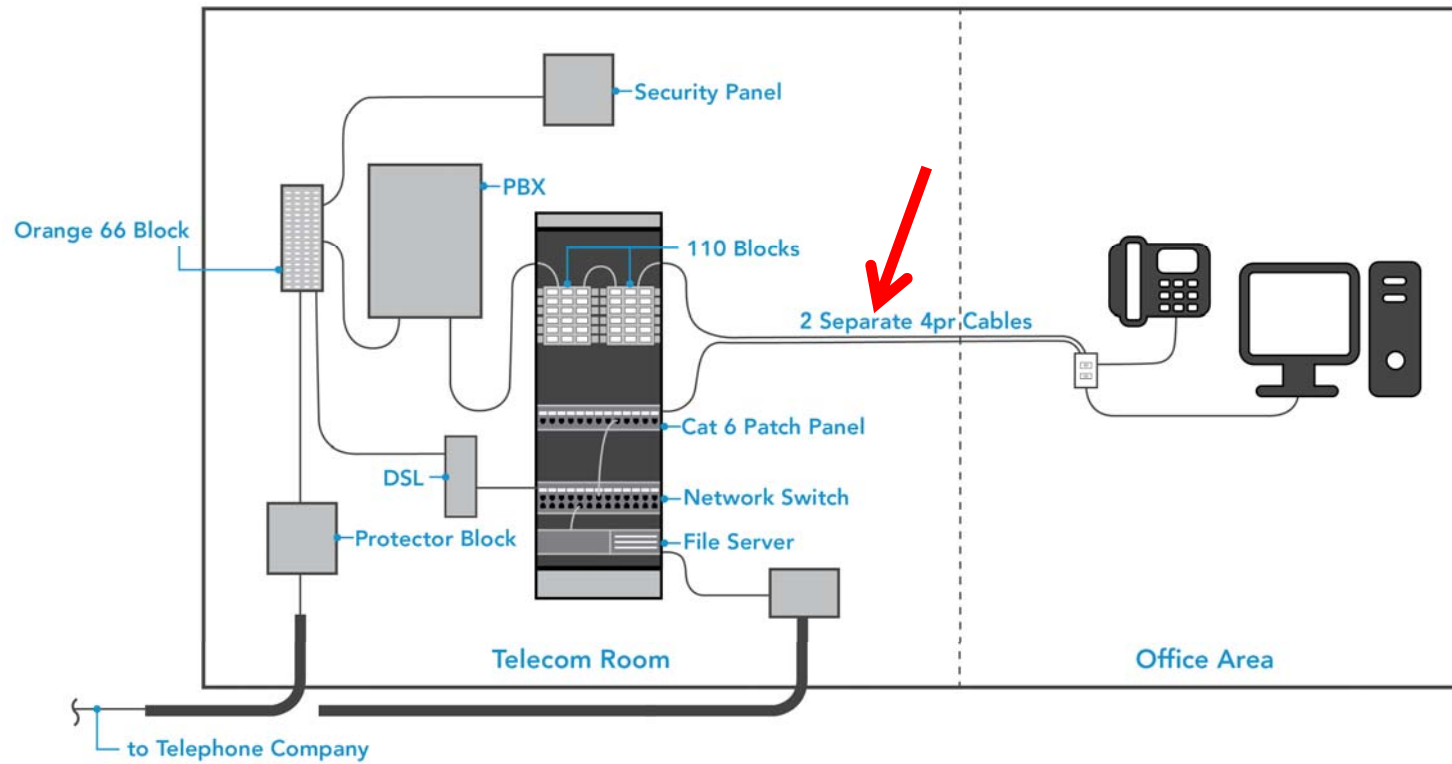

Understanding Article 800

800.1 Scope. *This article covers communications circuits and equipment.*

Informational Note No. 1: See 90.2(B)(4) for installations of communications circuits and equipment that are not covered.

Informational Note No. 2: For further information for remote-control, signaling, and power-limited circuits, see Article 725.

Informational Note No. 3: For further information for fire alarm systems, see Article 760.

- Informational notes identify what is not in scope for Article 800.

Understanding Article 800

- The scope in description is brief.
 - **800.1 Scope.** *This article covers communications circuits and equipment.*
- What is a “Communication Circuit”?
- General knowledge of what a communication circuit is does not matter. What does matter is what the NEC defines as a Communication Circuit.
- Let’s look at 800.2 Definitions

Understanding Article 800

- *800.2 Definitions*

800.2 Definitions See Part 1 of Article 100. For the purposes of this article, the following additional definitions apply.

Communications Circuit. *The circuit that extends voice, audio, video, data, interactive services, telegraph (except radio), outside wiring for fire alarm and burglar alarm from the communications utility to the customer's communications equipment up to and including terminal equipment such as a telephone, fax machine, or answering machine.*

- To assist in interpreting this definition:
 - Re-write the sentence to make it easier to understand but do not change the meaning.
 - For items in a list break out the listed items or write the sentence out several times using each listed item individually.

Understanding Article 800

- **Communications Circuit.**

The circuit that extends:

- *voice*
- *video*
- *interactive services,*
- *outside wiring for fire alarm*
- *audio*
- *data*
- *telegraph (except radio)*
- *and burglar alarm*

from the communications utility to the customer's communications equipment up to and including terminal equipment such as

- *a telephone*
- *fax machine*
- *or answering machine.*

Understanding Article 800

- Voice
- Audio
- Video
- Data
-

- Communications Circuit. The circuit that extends (a service) ... from the communications utility to the customer's communications equipment up to and including terminal equipment such as a fax machine....
- The key to understanding this definition is to recognize a communication circuit is defined as “extending from a communication utility”.

Understanding Article 800

- **Therefore if the Scope of 800 is** *“This article covers communications circuits and equipment.”, per the definition of a communication circuit:*
 - ***This article covers*** The circuit that extends (a service) ... from the communications utility to the customer’s communications equipment....
 - *Are the circuits in the diagram being extended from the utility?*

Interpretation Example

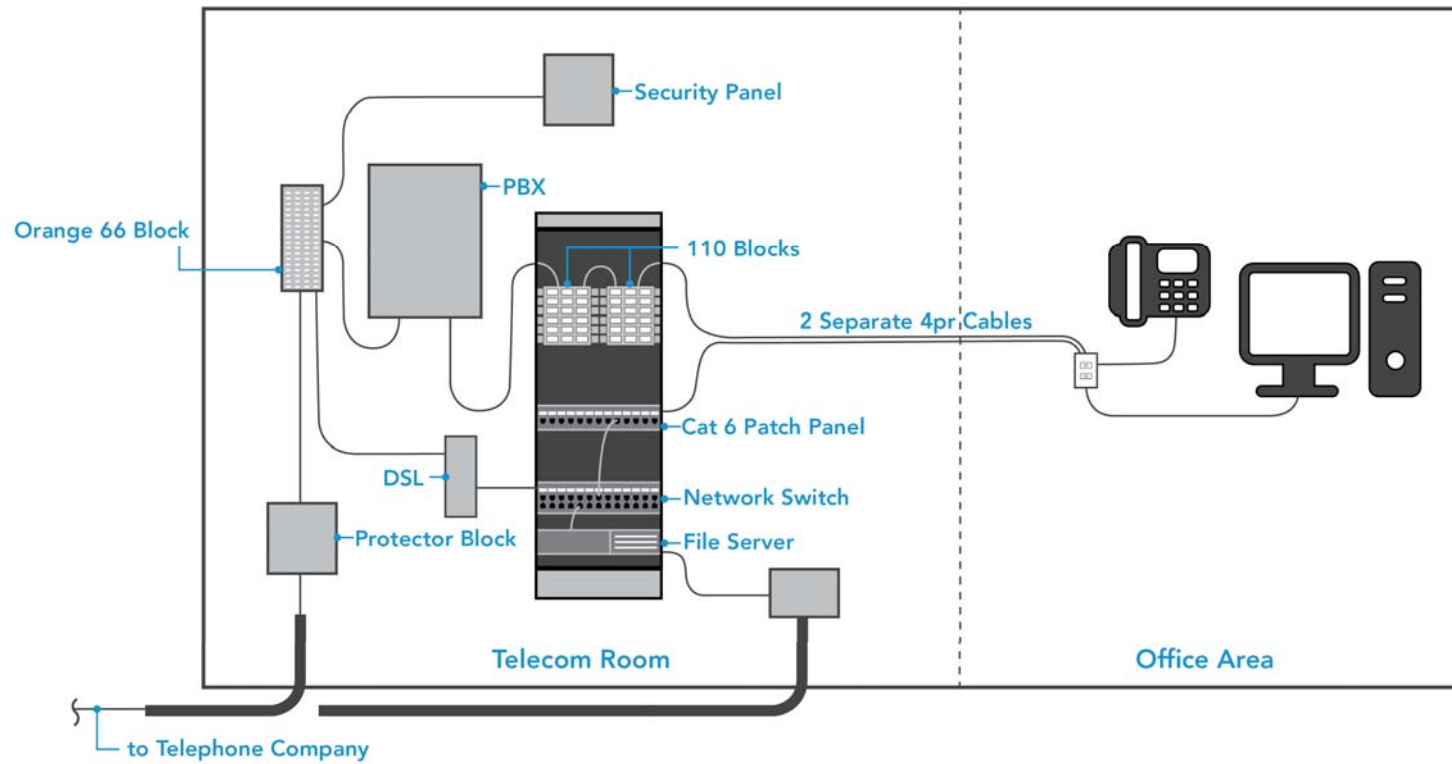

Understanding Article 800

- **From the NEC® Handbook (800.1 Scope):**

Although information technology equipment systems are often used for or with communications systems, Article 800 does not cover the wiring of this equipment.

See Also:

Article 645 provides requirements for wiring contained solely within an information technology equipment (computer) room. (See 645.4 for a description of the type of information technology equipment room to which Article 645 applies.)

Article 725 provides requirements for wiring that extends beyond a computer room and also covers wiring of local area networks within buildings.

Article 760 covers wiring requirements for fire alarm systems.

Understanding Article 800

From the NEC® Handbook (800.1 Scope):

Section 90.3 specifies that Chapter 8 covers communications systems and is not subject to the requirements of Chapters 1 through 7, other than where Chapter 8 specifies a requirement. In some cases, telephone system wiring is also used for data transmission, which is covered by Article 800. However, 90.2(B)(4) exempts telephone company central offices from Article 800. Exhibit 800.1 shows an example of the type of equipment that is subject to the requirements of Article 800.

In the 2017 NEC® Handbook, the editor removed “Communications equipment, such as private branch exchange shown in Exhibit 800.1, and all of the premises wiring for communication circuits, are subject to the requirements of Article 800.”

Answer to our Question

- Our Question:
 - Does Article 800 apply to the installation of a Category 6 cable from a network switch and PBX to a workstation outlet?
- Answer (interpretation):
 - The Category 6 data cable from the network switch is not covered by 800 but instead covered by 725.
 - The Category 6 cable from the PBX to the outlet is covered by Article 800 if the PBX is owned by the Utility or extends a circuit from the utility.

Answer to our Question

- Answer Continued:
 - The Category 6 cable from the PBX to the outlet is covered by Article 725 if the PBX is privately owned. Per the definition of a communications circuit, the circuit stops at the customers equipment.
 - Note: The NEC® 2014 Handbook, may also be covered by Article 800. Per the NEC® 2017 Handbook, it may not be covered by 800.
 - If the telephone circuit was a customer owned VOIP circuit, it would be covered by Article 725.
 - If the telephone circuit was a Utility owned VOIP circuit, it would be covered by Article 800.

Interpretation Example

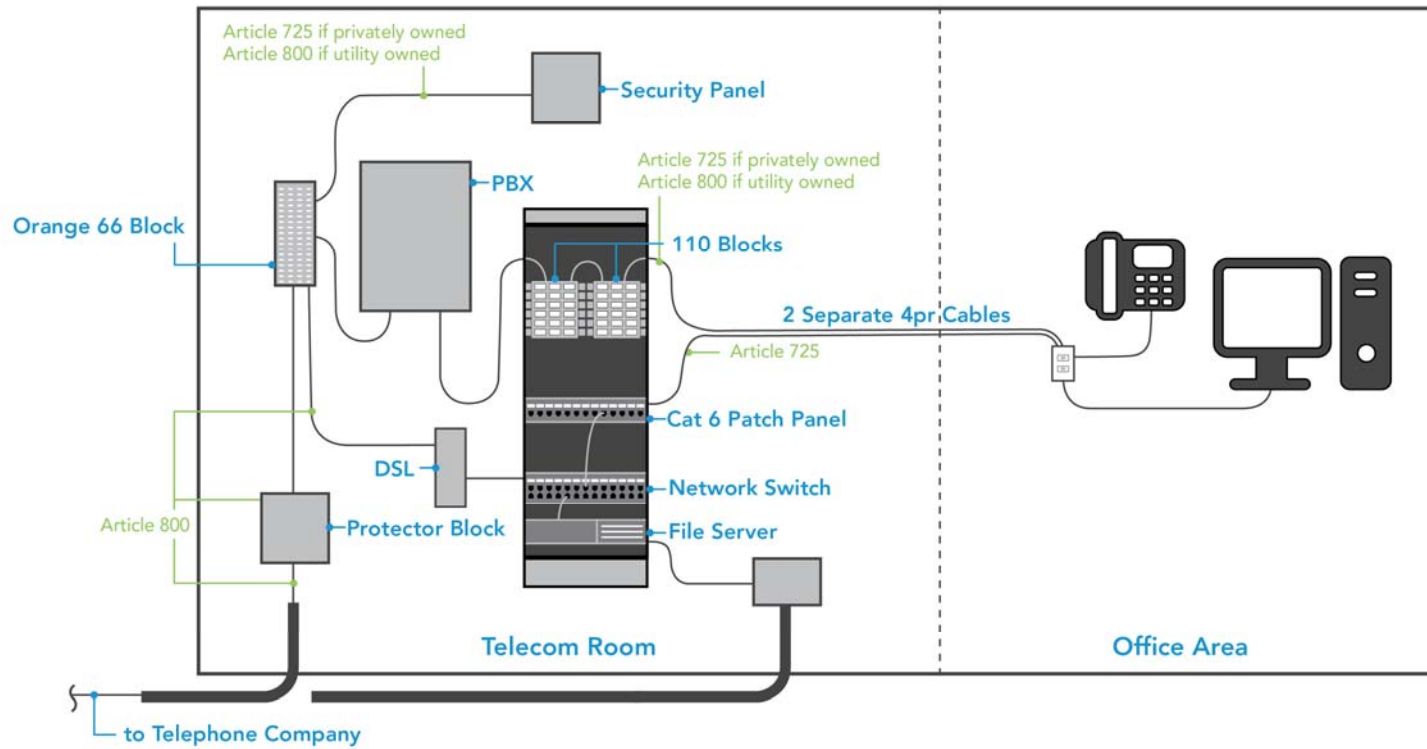

Interpretation Summary

- Review the Definitions as Defined by the NEC. Don't rely on conventional wisdom or trade knowledge.
- When interpreting run-on sentences with lists of items, carefully examine the sentence to interpret the meaning.
- Use the NEC Handbook as an expert opinion.



Article 725 Defined

- **Article 645 Information Technology Equipment**

645.1 Scope. This article covers equipment, power-supply wiring, equipment interconnecting wiring, and grounding of information technology equipment and systems in an information technology equipment room.

- **645.3 Other Articles**

(D) Electrical Classification of Data Circuits. Section 725.121(A)(4) shall apply to the electrical classification of listed information technology equipment signaling circuits. Sections 725.139(D)(1) and 800.133(A)(1) (c) shall apply to the electrical classification of Class 2 and Class 3 circuits in the same cable with communications circuits.

Article 725 Defined



- **From the NEC® Handbook (Article 725. 1 Scope)**

The installation requirements for the low-voltage wiring of information technology equipment (electronic data processing and computer equipment) located within the confines of a room that is constructed according to the requirements of NFPA 75, Standard for the Protection of Information Technology Equipment, are not covered by Article 725. Low-voltage wiring within these specially constructed room is covered by Article 645.

In addition, if listed computer equipment is interconnected and all the interconnected equipment is in close proximity, the wiring considered and integral part of the equipment and therefore not subject to the requirements of Article 725. If the wiring leaves the group of equipment to connect to other devices in the same room or elsewhere in the building, the wiring is considered “wiring within buildings” and is subject to the requirements of Article 725.

Question to the panel question: Is A/V cabling included in Article 725? True or False

Article 725 Defined

- Article 725 segmented into 4 parts
 - I. General
 - II. Class 1 Circuits
 - III. Class 2 and Class 3 Circuits
 - IV. Listing Requirements
- Note: Article 725 does not directly address cables coming in from a utility.

Article 725 Defined

- **Article 725 Class 1, Class 2 and Class 3 Remote-Control, Signaling, and Power- Limited Circuits**
 - LANs: Ethernet Networks, Token Ring, Arcnet, Latticenet are class 2 or class 3 power limited circuits as defined by their UL listing as information technology equipment or their power supplies.
- **725.2 Definitions.**

Class 2 Circuit. The portion of the wiring system between the load side of a Class 2 power source and the connected equipment. Due to its power limitations, a Class 2 circuit considers safety from a fire initiation standpoint and provides acceptable protection from electrical shock.

Article 725 Defined

- **725.2 Definitions.**

Class 3 Circuit. The portion of the wiring system between the load side of a Class 3 power source and the connected equipment. Due to its power limitations, a Class 3 circuit considers safety from a fire initiation standpoint. Since higher levels of voltage and current than for Class 2 are permitted, additional safeguards are specified to provide protection from an electric shock hazard that could be encountered.

- Note: Class 2 and Class 3 circuits have almost identical cabling requirements.

Article 725 Defined

- **Article 725.121 Power Sources for Class 2 and Class 3 Circuits.**

(A) Power Source. A power source for a Class 2 or Class 3 circuit shall be as specified in 725.121(A)(1), (A)(2), (A)(3), (A)(4), or (A)(5):

- (1) A Listed Class 2 transformer
- (2) A Listed Class 2 power supply
- (3) Other listed equipment marked to identify the Class 2 power source
- (4)[See next slide]
- (5) A dry cell battery shall be considered an inherently limited Class 2 power source, provided the voltage is 30 volts or less and the capacity equal to or less than that available from series connected No. 6 carbon zinc cells.

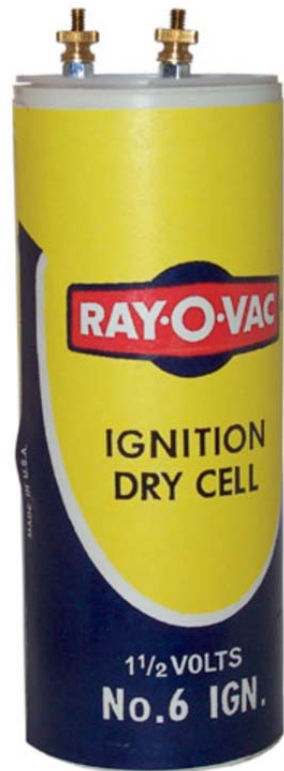

Article 725 Defined

- Article 725.121 Power Sources for Class 2 and Class 3 Circuits.



Article 725 Defined

- **Article 725.121 Power Sources for Class 2 and Class 3 Circuits.**

(4) Listed audio/video information technology (computer), communications, and industrial equipment limited-power circuits.

Informational Note: One way to determine applicable requirements for listing of information technology (computer) equipment is to refer to UL 60950-1-2011, *Standard for Safety of Information Technology Equipment*. Another way to determine applicable requirements for listing of audio/video, information and communication technology equipment is to refer to UL 62368-1-2014, Safety of audio/video, information and communication technology equipment. Typically such circuits are used to interconnect information technology equipment data circuits for the purpose of exchanging information data. One way to determine applicable requirements for listing of industrial equipment is to refer to UL 61010-2-201, Safety requirements for electrical equipment for measurement, control, and laboratory use –Part 2-201: Particular requirements for control equipment, and/or UL 61800-5-1, Adjustable speed electrical power drive systems – Part 5-1: Safety requirements –Electrical, thermal and energy.

Answer to the panel question: Is A/V cabling included in Article 725? True

Article 725 Defined

- The power supply type and the UL listing defines the cabling requirements for our LAN data circuits.
- Do not confuse a NEC 725 Class 2 circuit with an IEEE 802.3af Type 2 circuit. They are not the same although they both have to do with power and network cabling.
- IEEE 802.3af defines the power levels for Power over Ethernet.
- Network equipment will often be marked with a Class 2 power supply or will be UL listed under UL 60950-1. New product may be marked as compliant to IEC 62368-1.

Article 725 Defined

Item	Specification
Regulatory compliance	<ul style="list-style-type: none">• EMC compliance• FCC Part 15 (CFR 47) (USA) Class A• ICES-003 (Canada) Class A• EN55022 (Europe) Class A• CISPR22 (International) Class A• AS/NZS CISPR22 (Australia and New Zealand) Class A• VCCI (Japan) Class A• KN22 (Korea) Class A• CNS13438 (Taiwan) Class A• CISPR24• EN55024• EN50082-1• EN61000-3-2• EN61000-3-3• EN61000-6-1• EN300 386• EN61000-4-5
Safety	<ul style="list-style-type: none">• UL/CSA/IEC/EN 60950-1 • AS/NZS 60950

Cisco Product Data Sheet – Nexus 7700 Chassis

- Example of UL listing: Text from Cisco's product data sheet for their Nexus 7700 Chassis.

Articles 725 and 800 Similarities for Wiring Methods

- Remember:
 - For Telephone; Chapter 8 is stand alone unless it specifically references another section of the Code.
 - For Data; Apply Chapters 1, 2, 3 & 4 unless excluded or limited by Article 725.

Article 725.3 Other Articles. Circuits and equipment shall comply with the articles or sections listed in 725.3(A) through (N). Only those sections of Article 300 referenced in this article shall apply to Class 1, Class 2, and Class 3 circuits.

- For example:
 - 300.17 for the “Number and Size of Conductors in a Raceway” is included, but 300.14 “Length of Free Conductors at Outlets, Junctions and Switch Points” is not included and therefore does not apply. (e.g. 6” of conductor out of the box)

Articles 725 Limited Reference to Other Articles

- Article 725.3 Other Articles

- Number and Size of Conductors in Raceway. 300.17
- Spread of Fire or Products of Combustion: 300.21
- Ducts, Plenums, and Other Air-Handling Spaces: 300.22
- Hazardous (Classified) Locations. 500-516 and 517 Part IV
- Cable Trays: 392
- Motor Control Circuits: 430, Part IV
- Instrument Tray Cable: 727
- Raceways Exposed to Different Temperatures 300.7(A)
- Vertical Support for Fire-Rated Cables and Conductors: 300.19
- Bushing: 300.15 C
- Installation of Conductors with Other Systems: 300.8
- Corrosive, Damp, Wet Locations: 110:11, 300.5(B), 300.6, 300.9, 310(G)
- Cable Routing Assemblies: 800.154C, 800.182, 800.110C, 800.113
- Communication Raceways: 800.154C, 800.182, 800.110C, 800.113, 362.24 and 362.56 for ENT

Articles 725 and 800 Similarities for Wiring Methods

- Chapter 8 lists all of Part IV for grounding methods and has several references back to Article 250.
- Article 725 has no specific references back to Article 250 and takes no exceptions to Chapter 2 as was done for parts of Chapter. 3
- Even though Articles 725 and 800 have a different approach to excluding or including Chapters 1 through 4, the sections that apply to each are almost identical.



Classification of Cable

Cables are required to be “listed”. This is a designation marked on the cable indicating its construction and intended use per the NEC®.

Listed Cable” Required in Article 725.135(A) and 800.113 (A)

725.135 Installation of Class 2, Class 3 and PLTC Cables

(A) Listing. Class 2, Class 3, and PLTC cables installed in buildings shall be listed.

800.113 (A) Installation of Communications Wires, Cables and Raceways, and Cable Routing Assemblies.

(A) Listing. Communications wires, communications cables, communications raceways, and cable routing assemblies installed in buildings shall be listed.

Classification of Cable

Cable Type	Article 725	Article 800	Substitution
Plenum	CL2P or CL3P	CMP	CMP for CL2P or CL3P
Riser	CL2R or CL3R	CMR	CMR for CL2R or CL3R
General Purpose	CL2 or CL3	CM	CM for CL2 or CL3
Limited Use	CL2X or CL3X	CMX	CMX for CL2X or CL3X

- Cable shown on the top have a higher fire resistivity than those below. A cable with a higher rating (plenum) can be substituted for a lower rating (riser or general purpose).
- A CM Cable can be substituted for a CL cable.
- A CL Cable cannot be substituted for a CM Cable

Classification of Cable

- Article 800 doesn't allow for CL2 to be substituted for CM. Therefore we predominantly see cables marked only with CM.
- Article 800.48 Unlisted Cables Entering a building.
 - e.g. PE39 and PE89 listed by REU but not the NEC.
 - Unlisted cables discussed more in Part 2 of this seminar

Classification of Cable – LP Suffix

- New Listing for Limited Power Cables, 725.179 (I)

(I) Limited Power (LP) Cables. Limited power (LP) cables shall be listed as suitable for carrying power and data circuits up to a specified current limit for each conductor without exceeding the temperature rating of the cable where the cable is installed in cable bundles in free air or installed within a raceway, cable tray, or cable routing assembly. The cables shall be marked with the suffix “-LP” with the ampere limit located immediately following the suffix LP, where the current limit is in amperes per conductor.

Informational Note: The ampere limit located immediately following the suffix LP is the ampacity of each conductor in a cable. For example, 1 ampere Class 2 limited-power cables would be marked CL2-LP (1.0A), CL2R-LP (1.0A), or CL2-LP (1.0A).

Classification of Cable – LP Suffix

- Article 800 has no LP suffix defined.
- Code allows for CL3P to be substituted for a CMP
 - CL3P-LP (0.5A) = CMP-LP (0.5A)
- 725.144 Transmission of Power and Data

725.144 Transmission of Power and Data. The requirements of 725.144(A) and (B) shall apply to Class 2 and Class 3 circuits that transmit power and data to a powered device. The requirements of Parts I and III of Article 725 and 300.11 shall apply to Class 2 and Class 3 circuits that transmit power and data. The conductors that carry power for the data circuits shall be copper. The current in the power circuit shall not exceed the current limitation of the connectors.

300.11 Securing and Supporting

Classification of Cable – LP Suffix

- 725.144

(A) Use of Class 2 or Class 3 Cables to Transmit Power and Data. Where Types CL3P, CL2P, CL3R, CL2R, CL3, or CL2 transmit power and data, the following shall apply, as applicable:

(1) The ampacity ratings in Table 725.144 shall apply at an ambient temperature of 30°C (86°F).

(2) For ambient temperatures above 30°C (86°F), the correction factors of 310.15(B)(2) shall apply.

Informational Note: One example of the use of Class 2 cables is a network of closed circuit TV cameras using 24 AWG, 60°C rated, Type CL2R, Category 5e local area network (LAN) cables.

Classification of Cable – LP Suffix

Table 725.144 Ampacities of Each Conductor in Amperes in 4-Pair Class 2 or Class 3 Data Cables Based on Copper Conductors at an Ambient Temperature of 30°C (86°F) with All Conductors in All Cables Carrying Current, 60°C (140°F), 75°C (167°F), and 90°C (194°F) Rated Cables

AWG	Number of 4-Pair Cables in a Bundle																				
	1			2-7			8-19			20-37			38-61			62-91			92-192		
	Temperature Rating			Temperature Rating			Temperature Rating			Temperature Rating			Temperature Rating			Temperature Rating					
	60°C	75°C	90°C	60°C	75°C	90°C	60°C	75°C	90°C	60°C	75°C	90°C	60°C	75°C	90°C	60°C	75°C	90°C	60°C	75°C	90°C
26	1	1	1	1	1	1	0.7	0.8	1	0.5	0.6	0.7	0.4	0.5	0.6	0.4	0.5	0.6	0.4	0.5	0.6
24	2	2	2	1	1.4	1.6	0.8	1	1.1	0.6	0.7	0.9	0.5	0.6	0.7	0.4	0.5	0.6	0.3	0.4	0.5
23	2.5	2.5	2.5	1.2	1.5	1.7	0.8	1.1	1.2	0.6	0.8	0.9	0.5	0.7	0.8	0.5	0.7	0.8	0.4	0.5	0.6
22	3	3	3	1.4	1.7	2.1	1	1.2	1.4	0.7	0.9	1.1	0.6	0.8	0.9	0.6	0.8	0.9	0.5	0.6	0.7

Increase Current (blue arrow pointing left from 22 AWG, 1 cable to 22 AWG, 3 cables)

Decrease Current (red arrow pointing right from 22 AWG, 3 cables to 26 AWG, 1 cable)

Note 1: For bundles of 3 or more cables, ampacities shall be permitted to be determined by qualified personnel under direct supervision.

Note 2: Where only half of the conductors in each cable are carrying current, the values in the table shall be permitted to be increased by a factor of 1.4.

Heat = Power, $V=IR$, $P=VI$, $P=IRI$ or $P=I^2R$,
 @20 Ohms DC per loop, $P=(0.5)^2 \times 20=5W$, 4pr: $4 \times 5W = 20W$

Table from NEC® 2017

Classification of Cable – LP Suffix

- 725.144

(B) Use of Class 2-LP or Class 3-LP Cables to Transmit Power and Data. Types CL3P-LP, CL2P-LP, CL3R-LP, CL2R-LP, CL3-LP, or CL2-LP shall be permitted to supply power to equipment at a current level up to the marked ampere limit located immediately following the suffix LP and shall be permitted to transmit data to the equipment. The Class 2-LP and Class 3-LP cables shall comply with the following, as applicable:

- (1) Cables with the suffix “-LP” shall be permitted to be installed in bundles, raceways, cable trays, communications raceways, and cable routing assemblies.
- (2) Cables with the suffix “-LP” and a marked ampere level shall follow the substitution hierarchy of Table 725.154(A) and Figure 725.154(A) for the cable type without the suffix “LP” and without the marked ampere level.
- (3) System design shall be permitted by qualified persons under engineering supervision.

Classification of Cable – LP Suffix

Table 725.144 Ampacities of Each Conductor in Amperes in 4-Pair Class 2 or Class 3 Data Cables Based on Copper Conductors at an Ambient Temperature of 30°C (86°F) with All Conductors in All Cables (194°F) Rated Cables

AWG	Number of 4-Pair									
	1			2-7			8-19			Temper
	Temperature Rating	Temperature Rating	Temperature Rating	Temperature Rating	Temperature Rating	Temperature Rating	Temperature Rating	Temperature Rating	Temperature Rating	
60°C	75°C	90°C	60°C	75°C	90°C	60°C	75°C	90°C	60°C	
26	1	1	1	1	1	1	0.7	0.8	1	0.5
24	2	2	2	1	1.4	1.6	0.8	1	1.1	0.6
23	2.5	2.5	2.5	1.2	1.5	1.7	0.8	1.1	1.2	0.6
22	3	3	3	1.4	1.8	2.1	1	1.2	1.4	0.7

Note 1: For bundle sizes over 192 cables, or for conductor sizes smaller than personnel under engineering supervision.

Note 2: Where only half of the conductors in each cable are carrying current 1.4.

Informational Note 2: An example of a limited power (LP) cable is a cable marked Type CL2-LP(0.5A), 23 AWG.

A Type CL2-LP(0.5), 23 AWG could be used in any location where a Type CL2 could be used; however, the LP cable would be suitable for carrying up to 0.5 A per conductor, regardless of the number of cables in a bundle. (or) If used in a 7-cable bundle, the same cable could carry up to 1.2 amperes per conductor.

Table from NEC® 2017

Classification of Cable

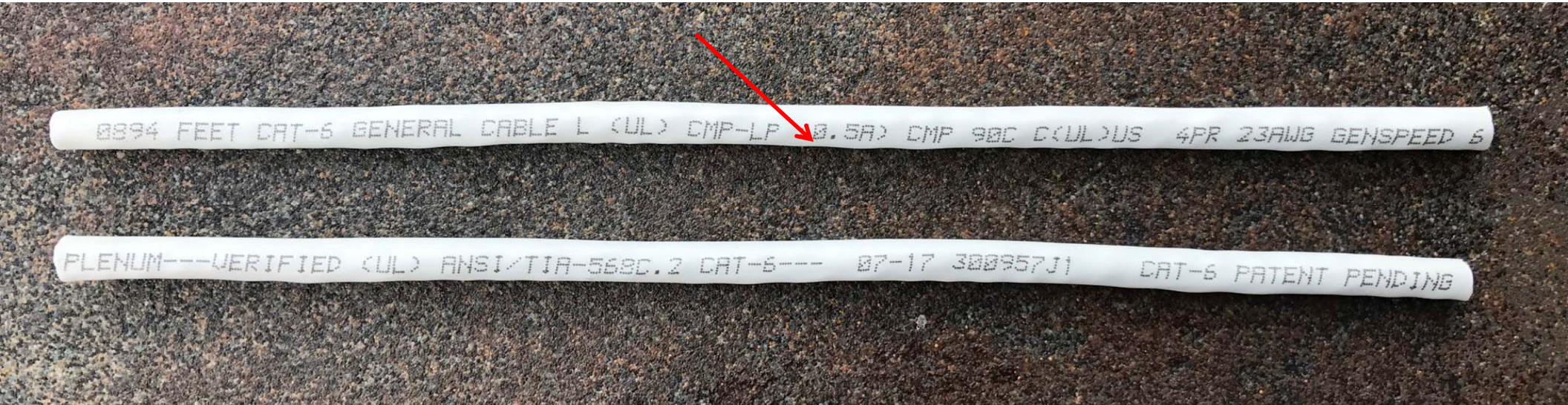

Question for the panel question: If a Class 2 or Class 3 cable and communication cable are routed in the same cable tray, Can you consider all the cables communication cables? True or False?

Classification of Cable

- 725.139 (D) Class 2 and Class 3 Circuits with Communication Circuits.

(1) Classified as Communications Circuits. Class 2 and Class 3 circuit conductors shall be permitted in the same cable with communications circuits, in which case the Class 2 and Class 3 circuits shall be classified as communications circuits and shall be installed in accordance with the requirements of Article 800. The cables shall be listed as communications cables.

Classification of Cable

- 725.139 (D) Class 2 and Class 3 Circuits with Communication Circuits.

(1) Classified as Communications Circuits. Class 2 and Class 3 circuit conductors shall be permitted in the same cable with communications circuits, in which case the Class 2 and Class 3 circuits shall be classified as communications circuits and shall be installed in accordance with the requirements of Article 800. The cables shall be listed as communications cables.

- 800.133.(A)(1)(b): Similar language as 725.139 (D) above
- Class 2 cables in the same cable tray or raceway with communications cables are not all communications cables.

Answer to the panel question: If a Class 2 or Class 3 cable and communication cable are routed in the same cable tray, can you consider all the cables communication cables? False

Classification of Cable

- Other cable classification we may see:
 - For Fiber Optics:
 - Non Conductive: OFN, OFNG, OFNR, OFNP
 - Conductive: OFC, OFCG, OFCR, OFCP
 - For Cable TV (CATV) Article 820.179: CATVP, CATVR, CATV, CATVX.
 - 820.154(E) allows substitutions by CM, BM and BL cables per table 820.154(b) (There is no BMP cable.)
- 725.179 (K) Class 2 and 3 cables will not have voltage markings.

Classification of Cable

- Cable Substitutions
 - In General, CMR listed cables can be substituted for many other cable listings

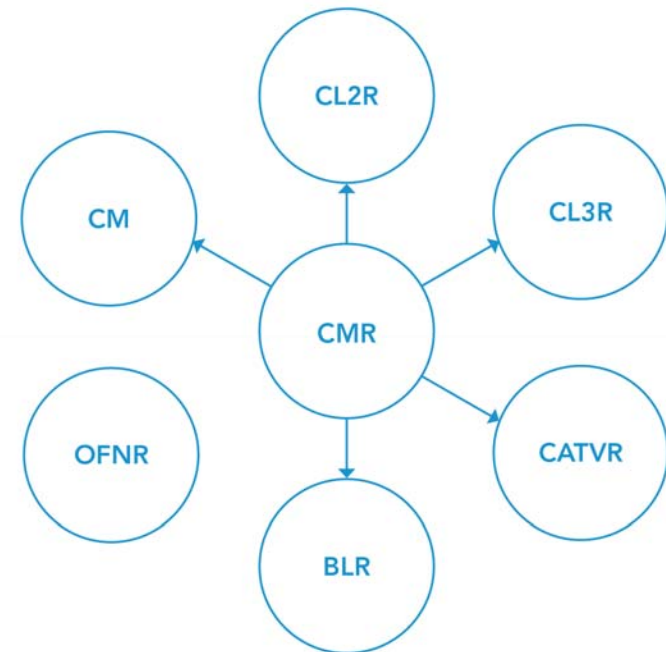



Plenum Spaces



- **Referenced in Table 725.154 Plenums, 770.113 & 800.113**

300.22 Wiring in Ducts Not Used for Air Handling, Fabricated Ducts for Environmental Air, and Other Spaces for Environmental Air (Plenums). The provisions of this section shall apply to the installation and uses of electrical wiring and equipment in ducts used for dust, loose stock, or vapor removal; ducts specifically fabricated for environmental air; and other spaces used for environmental air (plenums).

Question for the panel question: The Code has a special provision where non-Plenum cable is allowed to be exposed in a plenum area? True or False?
(Answer in 37 slides.)

Plenum Spaces

4 Categories of Ducts

- **300.22(A) Ducts for Dust, Loose Stock, or Vapor Removal**
 - No wiring systems of any type.
- **300.22(B) Ducts Specifically Fabricated for Environmental Air**
 - New Exception add in 2017 for equipment in the duct and limited to 4 ft in length.
- **300.22(C) Other Space Used for Environmental Air (Plenums).**
 - Space not specifically fabricated for air-handling but is used for air handling such as the space above a drop ceiling used for the return air path.
- **300.22(D) Information Technology Equipment**
 - Electrical wiring in air-handling areas beneath raised floors for information technology equipment shall be permitted in accordance with Article 645.

Plenum Spaces

- **Table 725.154A Applications of Listed Class 2, Class 3 and PLTC Cables in Buildings**

Table 725.154 Applications of Listed Class 2, Class 3, CMUC, and PLTC Cables in Buildings

Applications		Cable Type					
		CL2P & CL3P	CL2R & CL3R	CL2 & CL3	CL2X & CL3X	CMUC	PLTC
In fabricated ducts as described in 300.22(B)	In fabricated ducts	Y*	N	N	N	N	N
	In metal raceway that complies with 300.22(B)	Y*	Y*	Y*	Y*	N	Y*
In other spaces used for environmental air as described in 300.22(C)	In other spaces used for environmental air	Y*	N	N	N	N	N
	In metal raceway that complies with 300.22(C)	Y*	Y*	Y*	Y*	N	Y*
	In plenum communications raceways	Y*	N	N	N	N	N
	In plenum cable routing assemblies	Y*	N	N	N	N	N
	Supported by open metal cable trays	Y*	N	N	N	N	N
	Supported by solid bottom metal cable trays with solid metal covers	Y*	Y*	Y*	Y*	N	N

Updated for 2017. Used to be "Not Permitted"

Table from NEC® 2017

Plenum Spaces

- **800.113 (C)**

(C) Other Spaces Used for Environmental Air (Plenums).

The following wires, cables, and raceways shall be permitted in other spaces used for environmental air as described in 300.22(C):

- **770.113 (C)**

(C) Other Spaces Used for Environmental Air (Plenums).

The following cables shall be permitted in other spaces used for environmental air as described in 300.22(C):

Plenum Cable Routing Assemblies added for 2017

Plenum Spaces

- Cables installed Type CMP. Types CMP, CMR, CMG, CM and CMX installed per 300.22. (which means in a metal raceway or solid metal tray with a cover.)
- Article 300.22 (C)
 - (C) **Other Spaces Used for Environmental Air (Plenums).** This section shall apply to spaces not specifically fabricated for environmental air-handling purposes but used for air-handling purposes as a plenum. This section shall not apply to habitable rooms or areas of buildings, the prime purpose of which is not air handling.
 - Informational Note No 1: The space over a hung ceiling used for environmental air-handling purposes is an example of the type of other space to which this section applies.

Plenum Spaces

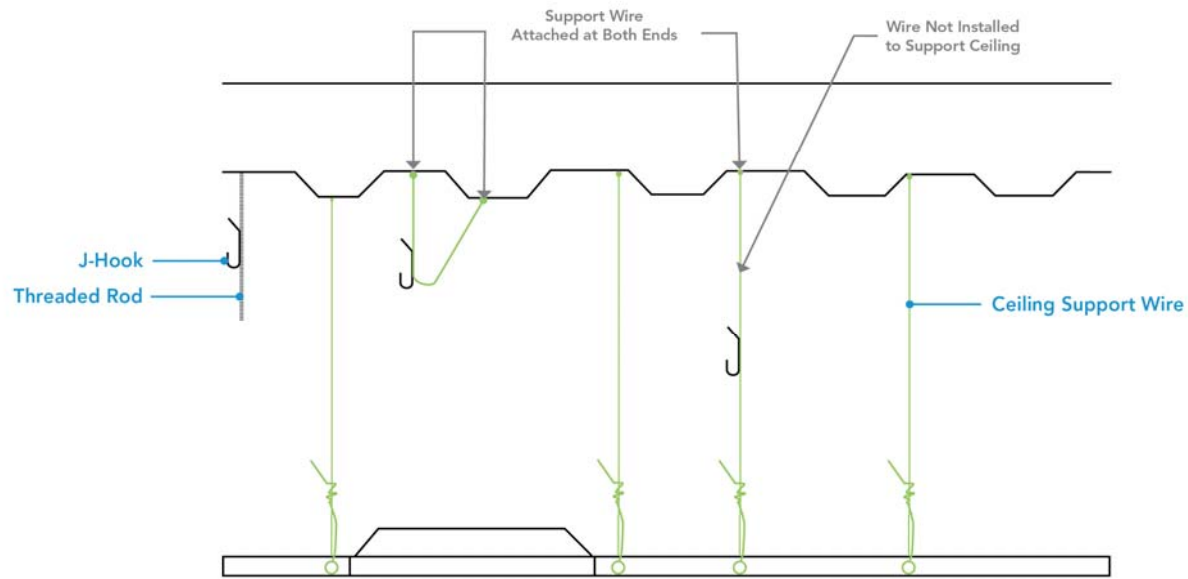

Typical T-Bar Drop Ceiling

Plenum Spaces

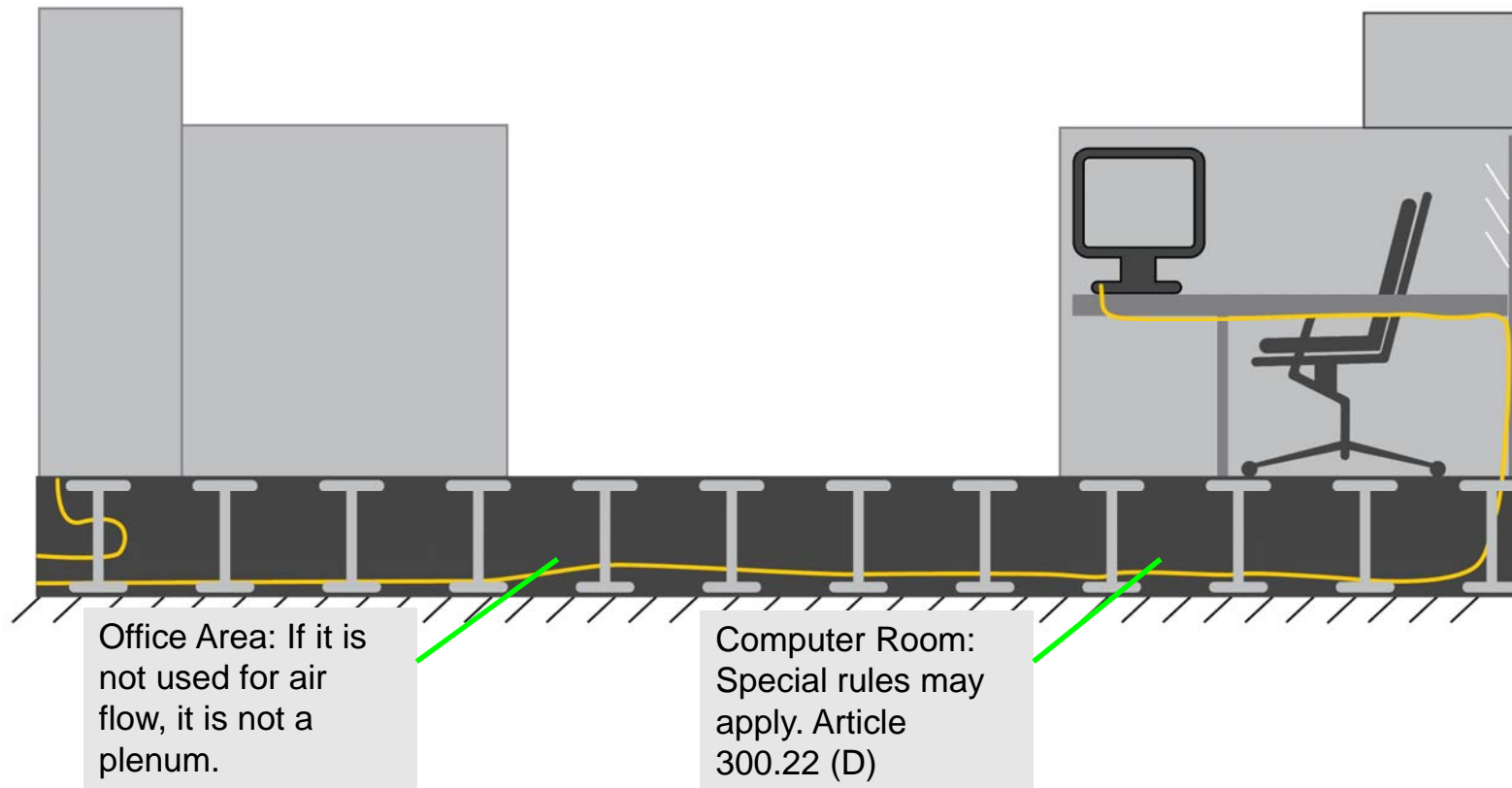

Plenum Spaces

- Cable Tray Systems addressed in **300.22 (C) (2)**

(2) Cable Tray Systems. The provisions in (a) or (b) shall apply to the use of metallic cable tray systems in other spaces used for environmental air (plenums), where accessible, as follows:

(a) *Metal Cable Tray Systems.* Metal cable tray systems shall be permitted to support the wiring methods in 300.22(C)(1).

(b) *Solid Side and Bottom Metal Cable Tray Systems.* Solid side and bottom metal cable tray systems with solid metal covers shall be permitted to enclose wiring methods and cables, not already covered in 300.22(C)(1), in accordance with 392.10(A) and (B).

Plenum Spaces

- Use type CL2P or CMP Cable when routed exposed.
- Use Listed cables installed in EMT, Flexible Metal Conduit and solid bottom metal cable tray with a metal cover. A plenum rated Communications Raceway allowed.
- Install equipment listed for use having adequate fire-resistant and low-smoke-producing characteristics.

Plenum Spaces

- 300.22 (C) Other Spaces Used for Environmental Air (Plenums)

(1) Wiring Methods. The wiring methods for such other space shall be limited to totally enclosed, nonventilated, insulated busway having no provisions for plug-in connections, Type MI cable without an overall nonmetallic covering, Type MC cable without an overall nonmetallic covering, Type AC cable, or other factory-assembled multiconductor control or power cable that is specifically listed for use within an air-handling space, or listed prefabricated cable assemblies of metallic manufactured wiring systems without nonmetallic sheath. Other types of cables, conductors, and raceways shall be permitted to be installed in electrical metallic tubing, flexible metallic tubing, intermediate metal conduit, rigid metal conduit without an overall nonmetallic covering, flexible metal conduit, or, where accessible, surface metal raceway or metal wireway with metal covers.

Nonmetallic cable ties and other nonmetallic cable accessories used to secure and support cables shall be listed as having low smoke and heat release properties.

Plenum Spaces

- Whether a space is being used to transport air or not, should be verified by the Architect, Mechanical Engineer or building owner.
- The presence of existing plenum rated cable is not a validation that it is a plenum space.
- The presence of firestopping appliances is not a validation that it is a plenum space.

Securing and Supporting of Conductors



- 800.24 Mechanical Execution of Work refers to 300.4(D) and 300.11
- 770.24 Mechanical Execution of Work refers to 300.4(D) and 300.11
- 725.24 Mechanical Execution of Work refers to 300.4(D) and 725.144 refers to 300.11
- 725.143 Support of Conductors refers to 300.11(C)(2)
 - Special case “Where the raceway contains power supply conductors for electrically controlled equipment and is used to support Class 2 circuit conductors or cables that are solely for the purpose of connection to the equipment control circuits.”

Question to the panel: We can use 14AWG ceiling support wire for hanging J hooks to support data and phone cabling? True or False?

Securing and Supporting of Conductors

300.11 Securing and Supporting

300.11 (A) (2)

(2) Non-Fire-Rated Assemblies. Wiring located within the cavity of a non-fire-rated floor-ceiling or roof-ceiling assembly shall not be secured to, or supported by, the ceiling assembly, including the ceiling support wires. An independent means of secure support shall be provided and shall be permitted to be attached to the assembly. Where independent support wires are used, they shall be distinguishable by color, tagging, or other effective means.

Answer to the panel question: We can use 14AWG ceiling support wire for hanging J hooks to support data and phone cabling? False.
Independent Wire, Yes. Ceiling support wire, No.

Securing and Supporting of Conductors

300.11 Securing and Supporting

Support Wires vs. Ceiling Support Wires

- (A) **Secured in Place.** Raceways, cable assemblies, boxes, cabinets, and fittings shall be securely fastened in place.
- (B) **Wiring Systems Installed Above Suspended Ceilings.** Support wires that do not provide secure support shall not be permitted as the sole support. Support wires and associated fittings that provide secure support and that are installed in addition to the ceiling grid support wires shall be permitted as the sole support. Where independent support wires are used, they shall be secured at both ends. Cables and raceways shall not be supported by ceiling grids.

The Code recognizes the difference between “securing” and “supporting”.

Securing and Supporting of Conductors

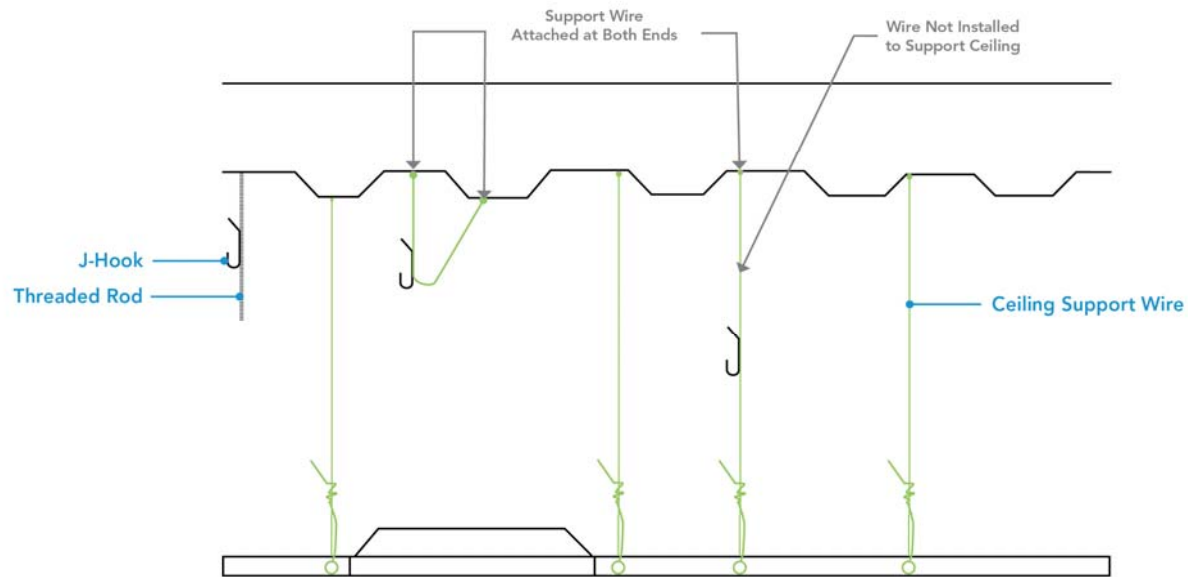

Typical T-Bar Drop Ceiling

Securing and Supporting of Conductors

- **300.11 Securing and Supporting Summary**
 - Support wires that do not provide secure support cannot be used.
 - Cannot use the ceiling support wire to support cable.
 - When an independent wire is used it has to be supported at both ends.

Separation of Cables from other Conductors

- 725.136 Separation from Electric Light, Power, Class 1, Non-Power Limited Fire Alarm Conductors and Medium-Power Network-Powered Broadband Communications Cable

(A) General. Cables and conductors of Class 2 and Class 3 circuits shall not be placed in any cable, cable tray, compartment, enclosure, manhole, outlet box, device box, raceway, or similar fitting with conductors of electric light, power, Class 1, non-power-limited fire alarm circuits, and medium-power network-powered broadband communications circuits unless permitted by 725.136(B) through (I).

Question to the panel: Does the Code identify a Class 2 or 3 Circuit that cannot be routed with other types of Class 2 or 3 circuits? True or False?

Separation of Cables from other Conductors

- (B) Separated by barriers: This is a barrier designed to provide separation.
- (C) Raceway within Enclosures: A Class 2 Circuit can be installed in a raceway to provide separation from powered circuits in an enclosure.
- (D) Associated Systems Within Enclosures: They can enter the same enclosure if they solely connect to the equipment and if:
 - (1) the circuit is routed to maintain a $\frac{1}{4}$ inch separation
 - (2) the circuit is 150V to ground or less, the Class 2 cable is within its listed jacket and the Class 2 conductors out of the jacket are separated by a $\frac{1}{4}$ inch from the powered circuit. Or install the Class 2 as a Class 1 circuit.

Separation of Cables from other Conductors

- (E) Enclosures With a Single Opening: Where they are to solely to connect to the Class 2 equipment. Where they enter through a single tee, the Class 2 and powered circuit are separated by a continuous, firmly, fixed non-conductor such as flexible tubing.
- (F) Manholes: The following conditions must be met:
 - (1) The powered circuits are in metal enclosed cable or type UF cable.
 - (2) The Class 2 cable permanently separated from the powered circuits with a continuous and firmly fixed nonconductor such as flexible tubing.
 - (3) The Class 2 cables are permanently separated by the other power circuits being securely fastened to racks, insulators and approved supports.

Separation of Cables from other Conductors

- (G) Cable Trays:
 - Separated by a solid fixed barrier compatible with the cable tray material
 - Or where the Class 2 cable is installed in type MC cable
- (H) In Hoistways: Where the Class 2 cable is installed in RMC, RNC, IMC, Liquidtight Nonmetallic Conduit, or EMT. For elevators, as permitted by 620.21.
- (I) Other Applications:
 - Class 2 cables separated by 2 inches from powered circuits unless all the Class 2 or all the powered circuits are in a raceway or metal clad sheathed, nonmetallic sheathed or type UF cable.
 - Powered circuits and Class 2 cables are permanently separated by a continuous and firmly fixed non conductor or flexible tubing in addition to the cable insulation.

Separation of Cables from other Conductors

- 725.139 Installation of Conductors of Different Circuits in the Same Cable, Enclosure, Cable Tray, Raceway or Cable Routing Assembly.
- Allows for combining of Class 2, 3 and Communications (A) – (D)

(F) Class 2 or Class 3 Conductors or Cables and Audio System Circuits. Audio system circuits described in 640.9(C), and installed using Class 2 or Class 3 wiring methods in compliance with 725.133 and 725.154, shall not be permitted to be installed in the same cable, raceway, or cable routing assembly with Class 2 or Class 3 conductors or cables.

Note: Does not mention enclosure or cable tray

Answer to the panel question: Does the Code identify a Class 2 or 3 Circuit that cannot be routed with other types of Class 2 or 3 circuits? True

Separation of Cables from other Conductors

- In Article 800 there are two sections discussing the separation of cables.

800.47 Underground Communications Wires and Cables Entering Buildings. Underground communications wires and cables entering buildings shall comply with 800.47(A) and (B). The requirements of 310.10(C) shall not apply to communications wires and cables.

(A) Underground Systems with Electric Light or Power, Class 1, or Non-Powered-Limited Fire Alarm Circuit Conductors. **Underground** communications wires and cables in a raceway, handhole enclosure, or manhole containing electric light, power, Class 1, or non-power-limited fire alarm circuit conductors shall be in a section separated from such conductors by means of brick, concrete, or tile partitions or by means of a suitable barrier.

Updated in 2017 to use more common Code language for powered circuits

Separation of Cables from other Conductors

- 800.133 Installation of Communications Wires, Cables and Equipment.

(A) Separation from Other Conductors.

(1) In Raceways, Cable Trays, Boxes, Cables, and Enclosures, and Cable Routing Assemblies.

(a) *Other Circuits.* Communications cables shall be permitted in the same raceway, cable tray, box, enclosure or cable routing assembly with cables of any of the following:

- (1) Class 2 and Class 3 remote-control, signaling, and power-limited circuits in compliance with Parts I and III of Article 725
- (2) Parts I and III of Article 760
- (3) Nonconductive and conductive optical fiber cables in compliance with Parts I and V of Article 770

Para.
changed for
2017 but not
marked

Separation of Cables from other Conductors

(4) Community antenna television and radio distribution systems in compliance with Parts I and V of Article 820

(5) Low-power network-powered broadband communications circuits in compliance with Parts I and V of Article 830

- 800.133 Installation of Communications Wires, Cables and Equipment.
 - (A)(1)(d): Communications shall not be placed with Electric Light, Power, Class 1... in Raceways, Compartments and Boxes or similar fittings.
 - Exceptions:
 - No.1 Where separated by a permanent barrier or listed divider.
 - No. 2 Where power conductors are solely introduced for power supply to communications equipment. Power conductors shall maintain a $\frac{1}{4}$ inch separation from communication circuit conductors.

Separation of Cables from other Conductors

- 800.133 Installation of Communications Wires, Cables and Equipment.
 - (A)(2): Other Applications. Communication wires and cables shall be separated at least 2 inches from conductors of any electric light, power, Class 1...
 - Exceptions: Section 800.133(A)(2) shall not apply
 - Where either the power cables are in a raceway, metal sheathed, metal clad, non-metallic sheathed, type AC or type UF cables OR, all the communication circuits conductors are in raceway.
 - Where the communication wires and cables are permanently separated from power... by a continuous and firmly fixed non-conductor, such as porcelain tubes, flexible tubing in addition to the insulation on the wires.
 - TIA-569-C Table 6 provides separation criteria for cable performance.

Separation of Cables from other Conductors

ANSI/TIA-569-C

Table 6 – Recommended separation from power wiring for balanced twisted pair cabling

Power circuit type (sinusoidal 50/60 Hz)	Number of radial power circuits	Minimum recommended separation, mm (in) ¹				
		E1 (EFT/B = 500V)		E2 (EFT/B = 500 V), E3 (EFT/B = 1000 V)		
		Unscreened power ca- bles	Armored or screened power ca- bles ²	Unscreened power cables		Armored or screened power cables ²
Unshielded cable	Shielded cable					
120/230 Vac, 20 A 1-phase	1	0 (0)	0 (0)	50 (2)	1 (0.04) ³	0 (0)
	2	0 (0)	0 (0)	50 (2)	5 (0.2) ³	2.5 (0.1)
	3	0 (0)	0 (0)	50 (2)	10 (0.4) ³	5 (0.2)
	4	0 (0)	0 (0)	50 (2)	12 (0.5) ³	8 (0.2)
	5 – 15	0 (0) ³	0 (0)	50 (2)	50 (2)	25 (1)
	16 – 30	100 (4)	50 (2)	100 (4)	100 (4)	50 (2)
	31 – 60	200 (8)	100 (4)	200 (8)	200 (8)	100 (4)
	61 – 90	300 (12)	150 (6)	300 (12)	300 (12)	150 (6)
	≥ 91	600 (24)	300 (12)	600 (24)	600 (24)	300 (12)
120/230 Vac, 32 A 1-phase	1	10 (0.4) ³	5 (0.2)	50 (2)	10 (0.4) ³	5 (0.2)
	2	20 (0.8) ³	10 (0.4)	50 (2)	20 (0.8) ³	10 (0.4)
	3	30 (1) ³	15 (0.6)	50 (2)	30 (1) ³	15 (0.6)
	4 – 5	50 (2)	25 (1)	50 (2)	50 (2)	25 (1)
	6 – 9	100 (4)	50 (2)	100 (4)	100 (4)	50 (2)



Article 645 Information Technology Equipment

645.1 Scope. This article covers equipment, power-supply wiring, equipment interconnecting wiring, and grounding of information technology equipment and systems in an information technology equipment room.

Informational Note: For further information, see NFPA 75-2017, *Standard for the Protection of Information Technology Equipment*, which covers the requirements for the protection of information technology equipment and information technology equipment areas.

- What is the Code identifying as an information technology (IT) equipment and room?

Question to the panel: In general, Article 645 applies to Telecom Rooms?
True or False?

Article 645 Information Technology Equipment

- The NEC added in 2011 the definition for an IT equipment room. The key is to look at NFPA 75.

Information Technology Equipment Room. A room within the information technology equipment area that contains the information technology equipment.
[75:3.3.9]

- From NFPA 75 – Standard for the Protection of Information Technology Equipment

3.3.9 Information Technology Equipment Room. A room within the information technology equipment area that contains the information technology equipment.

- This may not have been very helpful.

Article 645 Information Technology Equipment

- The key is to look at NFPA 75. On Page 75-1 in the Origin Statement it says:

In editions of this standard prior to 2003, the terms “electronic computer/data processing equipment” and “electronic computer system” were used where the current terms “information technology equipment” and “information technology equipment system,” respectively, are used. Similarly, the terms “computer room” and “computer area” were replaced by “information technology equipment room” and “information technology equipment area,” respectively. While the title and some terminology were changed in the 2003 edition to more closely align this standard’s terminology with terminology being used in other standards, such as NFPA 70, *National Electrical Code*, and UL 60950, *Safety of Information Technology Equipment*, the scope of this standard and any definitions associated with those like terms remained the same.

Article 645 Information Technology Equipment

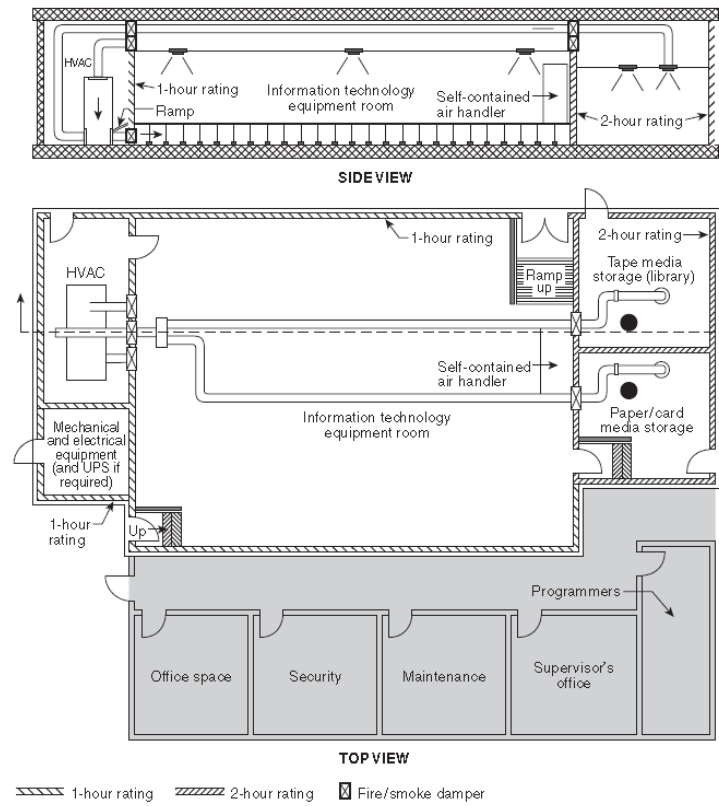

- Diagram from NFPA-75-2013, Annex A

Article 645 Information Technology Equipment

- Article 645 does not directly apply to Telecom Rooms or Equipment Rooms as defined by TIA-569B *Commercial Building Standard for Telecommunication Pathways and Spaces*.

NFPA 75, 1.3 Application.

1.3 Application. The application of this standard is based on the risk considerations outlined in Chapter 4.

1.3.1 A documented risk assessment shall be the basis for the implementation of this standard.

1.3.2 The mere presence of the information technology equipment shall not constitute the need to invoke the requirements of this standard.

Article 645 Information Technology Equipment

4.2.1 Telecommunications Risks for the Private Network.

4.2.1.1 To assess and evaluate the damage and interruption potential of the loss of information technology equipment room operations, a risk evaluation shall be conducted on the impact of the loss of data and communications.

4.2.1.2 The provisions of this standard shall apply to those areas housing telecommunications equipment that are part of a private network or where the need for protection has been determined by the risk evaluation outlined in 4.2.1.1.

- It may be applied if the risk assessment warrants it.

Answer to the panel question: In general, Article 645 applies to Telecom Rooms? False

Article 645 Information Technology Equipment

645.4 Special Requirements for Information Technology Equipment Room. The alternate wiring methods to Chapters 3 and Parts I and III of Article 725 for signaling wiring and Parts I and V of Article 770 for optical fiber cabling shall be permitted where all of the following conditions are met:

1. Disconnecting Power Means (Emergency Power Off Switch)
 2. A separate and dedicated HVAC system. (or smoke fire dampers at the boundary.)
 3. All IT equipment and communications equipment installed is listed.
 4. The room is occupied and accessible only by maintenance and operational staff that support the equipment.
 5. The room is separated from other spaces by fire rated walls, floors, ceilings and openings.
 6. Only electrical equipment and wiring associate with the room is installed.
- This does not read that you have to apply these requirements. You only apply these to take advantage of the other provisions of this Article, “the alternate wiring methods”.

Article 645 Information Technology Equipment

- 645.5 Supply Circuits and Interconnecting Cables
 - (E) Under Raised Access Floors

(2) Installation Requirements for Electrical Supply Cords, Data Cables, Interconnecting Cables, and Grounding Conductors Under a Raised Floor. The following cords, cables, and conductors shall be permitted to be installed under a raised floor:

- (1) Supply cords of listed information technology equipment in accordance with 645.5(B)
- (2) Interconnecting cables enclosed in a raceway
- (3) Equipment grounding conductors
- (4) In addition to wiring installed in compliance with 725.135(C), Types CL2R, CL3R, CL2, and CL3 and substitute cables including CMP, CMR, CM, and CMG installed in accordance with 725.154(A), shall be permitted under raised floors.

645.5 (E) (2) is a new paragraph replacing table 645.5 (E) (6) in the 2014 Edition

Other spaces used for environmental air. Calling out Plenum rated cable.

Article 645 Information Technology Equipment

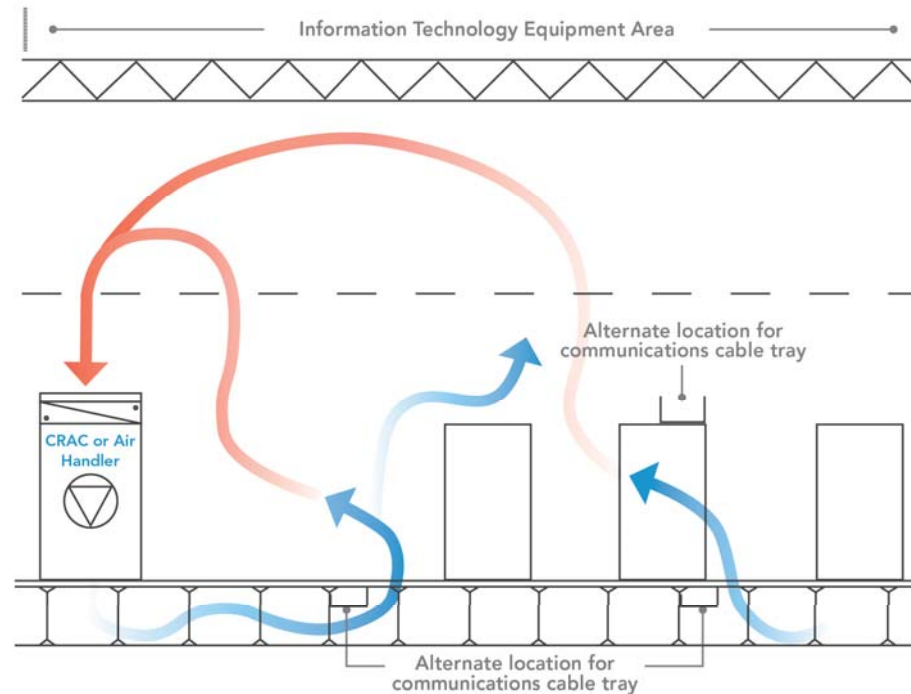

Information Technology Equipment Room - Traditional
(Computer Room/Data Center)

Article 645 Information Technology Equipment

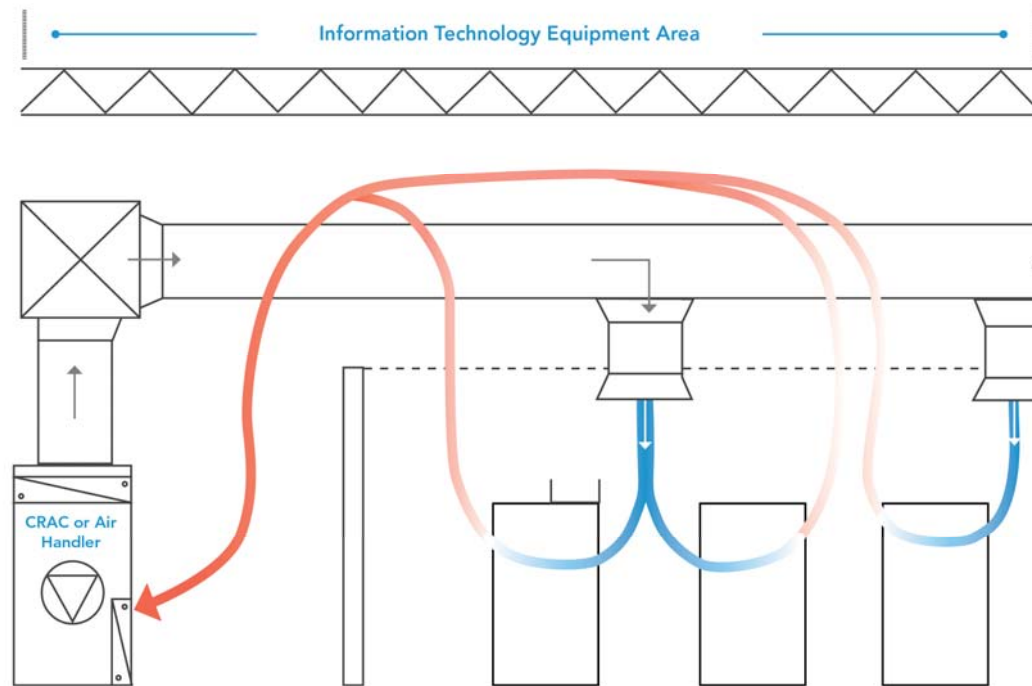

Information Technology Equipment Room Without a Raised Floor.

Article 645 Information Technology Equipment



Answer to the panel question: The Code has a special provision where non-Plenum cable is allowed to be exposed in a plenum area? True. If all the provisions of Article 645 are followed, listed non-plenum cable can be installed.

Bonus question: Does Article 645 apply to Modular Data Centers? True or False?



Article 645 Information Technology Equipment



Answer to the panel question: The Code has a special provision where non-Plenum cable is allowed to be exposed in a plenum area? True. If all the provisions of Article 645 are followed, listed non-plenum cable can be installed.

Bonus question: Does Article 645 apply to Modular Data Centers? False
Article 646 Modular Data Centers was added in the 2014 Edition.





Fiber Optic Cables



- NEC Article 770 is dedicated to this special type of cable.
- The Code recognizes its intrinsic properties of being a dielectric and having cable properties that are completely non-conductive.
- You can do some things with Fiber Optic Cable that cannot be done with any other types of telecommunications cabling. For example, per 770.133, under certain conditions a fiber optic cable can be routed with power cables.

Fiber Optic Cables

The 2017 Code moved several definitions to Article 100.

Optical Fiber Cable definition in 2014 was expanded to include a field assembled cable.

Article 100

Optical Fiber Cable. A factory assembly or field assembly of one or more optical fibers having an overall covering. (CMP-16)

Informational Note: A field-assembled optical fiber cable is an assembly of one or more optical fibers within a jacket. The jacket, without optical fibers, is installed in a manner similar to conduit or raceway. Once the jacket is installed, the optical fibers are inserted into the jacket, completing the cable assembly.

Fiber Optic Cables

OFNR: Optical Fiber Nonconductive Riser

Nonconductive Optical Fiber Cable. A factory assembly of one or more optical fibers having an overall covering and containing no electrically conductive materials.

OFNR: Optical Fiber Nonconductive Riser

Conductive Optical Fiber Cable. A factory assembly of one or more optical fibers having an overall covering and containing non-current-carrying conductive member(s) such as metallic strength member(s), metallic vapor barrier(s), metallic armor or metallic sheath.

A popular cable to install is an armored wrapped OFNR cable. The armor is conductive. Even though the inner fiber optic cable is jacketed from the manufacturer as OFNR, the overall listing with the armor is now OFCR.

Fiber Optic Cables

- 770.110 Raceways and Cable Routing Assemblies for Optical Fiber Cables

(3) Innerduct for Optical Fiber Cables. Listed plenum communications raceway, listed riser communications raceway, and listed general-purpose communications raceway selected in accordance with the provisions of Table 800.154(b) shall be permitted to be installed as innerduct in any type of listed raceway permitted in Chapter 3.

Note: Optical Raceway was replaced with Communications Raceway in 2014

- 770.24 Mechanical Execution of Work
 - References the same Articles as 725 & 800, Articles 300.4(D) through (G) and 300.11

Cable Tray Fill and Unlisted Cables discussed with the other cable types.



Raceway

- Article 100 Definitions

Raceway. An enclosed channel of ~~metallic or nonmetallic materials~~ designed expressly for holding wires, cables, or busbars, with additional functions as permitted in this Code.

***Informational Note:** A raceway is identified within specific article definitions.*

Communications Raceway. An enclosed channel of nonmetallic materials designed expressly for holding communications wires and cables; optical fiber cables; data cables associated with information technology and communications equipment; Class 2, Class 3, and Type PLTC cables; and power-limited fire alarm cables ; ~~typically communications wires and cables and optical fiber and data (Class 2 and Class 3)~~ in plenum, riser, and general-purpose applications.

Cable Routing Assembly. A single channel or connected multiple channels, as well as associated fittings, forming a structural system that is used to support and route communications wires and cables, optical fiber cables, data cables associated with information technology and communications equipment, Class 2 and Class 3 cables, and power limited fire alarm cables.

Raceway

- 300.17 Number and Size of conductors in a Raceway

The number and size of conductors in any raceway shall not be more than will permit dissipation of the heat and ready installation or withdrawal of the conductors without damage to the conductors or to their insulation.

Informational Note: See the following sections of this *Code*: intermediate metal conduit, 342.22; rigid metal conduit, 344.22; flexible metal conduit, 348.22; liquidtight flexible metal conduit, 350.22; PVC conduit, 352.22; HDPE conduit, 353.22; RTRC, 355.22; liquidtight nonmetallic flexible conduit, 356.22; electrical metallic tubing, 358.22; flexible metallic tubing, 360.22; electrical nonmetallic tubing, 362.22; cellular concrete floor raceways, 372.11; cellular metal floor raceways, 374.5; metal wireways, 376.22; nonmetallic wireways, 378.22; surface metal raceways, 386.22; surface nonmetallic raceways, 388.22; underfloor raceways, 390.6; fixture wire, 402.7; theaters, 520.6; signs, 600.31(C); elevators, 620.33; audio signal processing, amplification, and reproduction equipment, 640.23(A) and 640.24; Class 1, Class 2, and Class 3 circuits, Article 725; fire alarm circuits, Article 760; and optical fiber cables and raceways, Article 770.

Raceway

- Article 392 Cable Trays

392.2 Definition.

Cable Tray system. A unit or assembly of units or sections and associated fittings forming a structural system used to securely fasten or support cables and raceways.

- Note: Cable Trays are not raceways.



Raceway

- Article 800.110 Raceways and Cable Routing Assemblies for Communications Wires and Cables
 - Recognizes the raceway types and installation listed in Ch. 3 (EMT, IMC, RMC...) or
 - Recognizes communication raceway installed per 362.24 through 362.56 – Electrical Nonmetallic Tubing (ENT)
 - Listed Plenum, Riser & General Communications Raceway

(B) Raceway Fill for Communications Wires and Cables. The raceway fill requirements of Chapters 3 and 9 shall not apply to communications wires and cables.

Raceway

- 800.110 (C) Cable Routing Assemblies
- The 2011 NEC® Added Cable Routing Assemblies. The 2014 NEC® further defined these. 2017 NEC® expanded the use for plenum spaces.
- Defined parameters for horizontal and vertical support
 - Horizontal: Every 3 ft and each joint unless listed for a longer support but not to exceed 10 ft.
 - Vertical: Every 4 ft unless listed for a longer support and shall not have more than 1 joint between supports

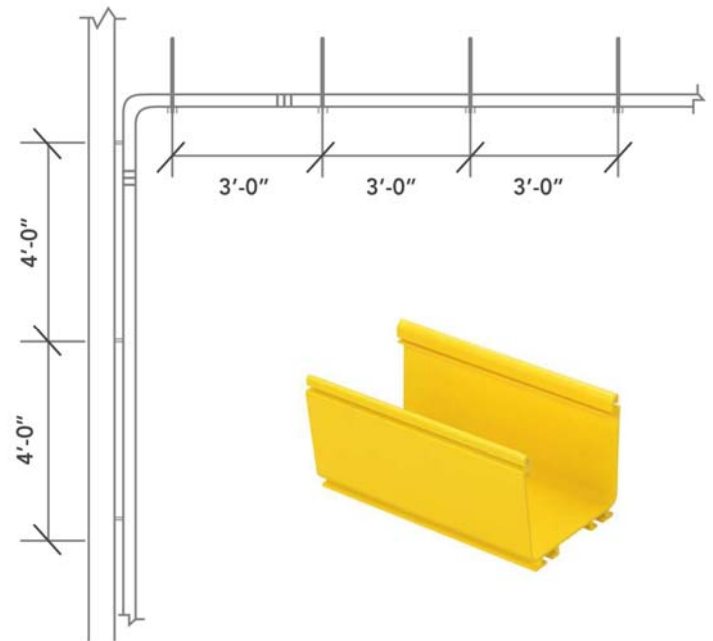

Raceway

- Article 725.24 Mechanical Execution of Work
 - Allows Class 2 circuits to be installed exposed on the surface of ceilings and side walls using the building structure for support and in accordance with 300.4(D). Note: Cables do not have to be in raceway.
 - 725.154 and Table 725.154 addresses Plenums, Risers and “Other Wiring Within Buildings”. Allows cable to installed in raceway, communication raceway and cable tray
 - 725.179 Edited for LP rated cable

Raceway

- 725.3 (A)

(A) Number and Size of Conductors in Raceway. Section 300.17.

- 300.17

300.17 Number and Size of Conductors in a Raceway. The number and size of conductors in any raceway shall not be more than will permit dissipation of the heat and the ready installation or withdrawal of the conductors without damage to the conductors or to their insulation.

- 300.17 Informational note: Lists all of the raceway types for the number and size of conductors.

Raceway

- Although 300.17 considers the number of conductors based on heat and other factors, Article 725 recognizes the cables in Article 725 as being different.

725.1 Scope. This article covers remote-control, signaling, and power-limited circuits that are not an integral part of a device or ~~appliance~~ of utilization equipment.

Informational Note: The circuits described herein are characterized by usage and electrical power limitations that differentiate them from electric light and power circuits; therefore, alternative requirements to those of Chapters 1 through 4 are given with regard to minimum wire sizes, ampacity adjustment and correction factors, overcurrent protection, insulation requirements, and wiring methods and materials.

Raceway

- Raceway fill tables are referenced in the different raceway sections. For example, in Article 358 EMT

358.22 Number of Conductors. The number of conductors shall not exceed that permitted by the percentage fill specified in Table 1, Chapter 9.

- Table 1, Chapter 9 states for over 2 cables the percent of cross section of conduit not to exceed 40%.
- Follow TIA/EIA 569-D for pathway fill and perimeter raceways for both Article 800 and 725 cables. In para 9.10.4 and 9.12.2.1.1 is 40% fill.

Raceway

TIA-569-B

Not included in TIA-569-C

8.8.2.3 Sizing

Conduits used for horizontal cables should be sized per table 9. Backbone conduits should be designed based on the fill specifications identified in table 10 or table 11, as appropriate.

NOTE – Conduit sizing may be affected when the cabling is used exclusively for computers (see Article 725 of the National Electrical Code).

Table 9 – Conduit sizing for horizontal cables

Conduit trade size	Maximum number of cables based upon allowable fill							
	Cable outside diameter, mm (in)							
	3.3 (.13)	4.6 (.18)	5.6 (.22)	6.1 (.24)	7.4 (.29)	7.9 (.31)	9.4 (.37)	13.5 (.53)
16 (½)	1	1	0	0	0	0	0	0
21 (¾)	6	5	4	3	2	2	1	0
27 (1)	8	8	7	6	3	3	2	1
35 (1¼)	16	14	12	10	6	4	3	1
41 (1 ½)	20	18	16	15	7	6	4	2
53 (2)	30	26	22	20	14	12	7	4

Raceway



- Article 770.110 Raceways for Optical Fiber Cables
 - Recognizes the raceway types and installation listed in Ch. 3 (EMT, IMC, RMC...) or
 - Recognizes “Communication” raceways installed per 362.24 through 362.56 – Electrical Nonmetallic Tubing (ENT)
 - Listed Plenum, Riser & General Communication Raceway
 - Added Cable Routing Assemblies.
 - Same definition and limits of 800.110 (C)

Question to the panel: Raceway fill table never apply to fiber optic cables? True or False?

Raceway

- 770.110 (B) Raceway Fill for Optical Cables.

(B)(2) Nonconductive Optical Fiber Cables with Electric Light or Power Conductors. Where nonconductive optical fiber cables are installed with electric light or power conductors in a raceway, the raceway fill requirements of Chapter 3 and 9 shall apply.

Answer to the panel question: Raceway fill table never apply to fiber optic cables? False?

Cable Tray

- Cable Tray used to support cable and raceways. 392.2
- Class 2 , Communications, Fiber Optic Cables, CATV and Radio Distribution System, Low-Power Network Powered Broadband Communication Circuits can be in the same cable tray.
 - 725.139(E)
 - 770.133 (B)
 - 800.133(A)(1)
 - 820.133 (A)(1)
 - 830.133 (A)(1)

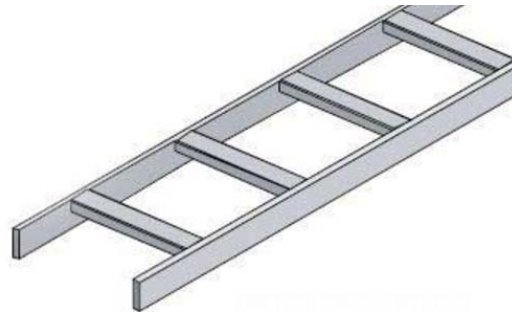

Cable Tray

- Cable Tray Fill
 - Articles 800, 820 and 830 do not address cable tray fill.
 - For these cables refer to TIA/EIA 569D
 - Article 770 address tray fill only when cables are routed with power conductors.
 - Article 725 references Article 392 Cables Trays directly in 725.3 (E).

Cable Tray

- Class 2 Cable – Cable Tray fill
 - 392.22 Number of Conductors or Cables
 - (A)(2) Ladder or Ventilated Trough Cable Trays Contain Multiconductor Control and/or Signal Cables.
 - 50% fill for Ladder or Ventilated with 6-inch usable fill depth or less.
 - (A)(4) Solid Bottom Cable Tray Containing Multiconductor Control and/or Signal Cable Cables Only.
 - 40% fill for Solid Bottom Tray, 6-inch usable fill depth or less

392.22 Number of Conductors or Cables.

(A) Number of Multiconductor Cables, Rated 2000 Volts or Less, in Cable Trays. The number of multiconductor cables, rated 2000 volts or less, permitted in a single cable tray shall not exceed the requirements of this section. The conductor sizes shall apply to both aluminum and copper conductors. Where dividers are used, fill calculations shall apply to each divided section of the cable tray.

Cable Tray

ANSI/TIA-569-D

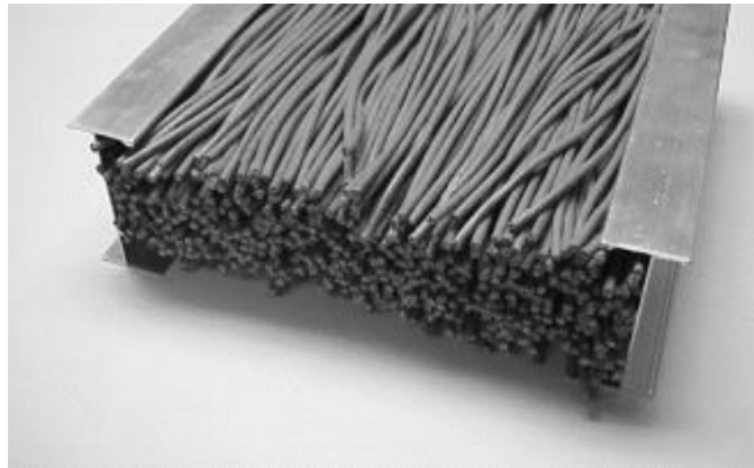

Figure 14 – Cable tray with 5.5 mm (0.22 in) diameter cables at 50% calculated fill

NOTE – This photograph does not constitute an endorsement by TIA or this Committee of the product in the image. Alternative products or technologies may be substituted.

Image and text from TIA 569-D

Cable Tray

- Article 392.56 allows for cable splices in a cable tray but does not identify cable terminations in a cable tray. Therefore it is assumed terminations in a tray are not allowed.
- Article 392.18 (G) Raceways, Cables, Boxes, and Conduit Bodies supported from Cable Tray Systems.
 - In industrial facilities where there is supervision to ensure qualified persons....
 - Boxes and conduit bodies can be supported from the bottom and side of the cable tray.

Cable Tray

- 392.60 Grounding and Bonding:

(A) Metallic Cable Trays. Metallic cable trays shall be permitted to be used as equipment grounding conductors where continuous maintenance and supervision ensure that qualified persons service the installed cable tray system and the cable tray complies with provisions of this section. Metallic cable trays that support electrical conductors shall be grounded as required for conductor enclosures in accordance with 250.96 and Part IV of Article 250. Metal cable trays containing only non-power conductors shall be electrically continuous through approved connections or the use of a bonding jumper.

Informational Note: Examples of non-power conductors include nonconductive optical fiber cables and Class 2 and Class 3 Remote Control Signaling and Power Limiting Circuits.



Unlisted Cables Entering a Building



- An unlisted cable is cable that does not have a listing recognized by the NEC or is not listed to be in a building.
- Example of listed cables:
 - CMR, CLP, OFNR, CATV, BLR
- Example of unlisted cables
 - PE39 and PE89 listed by REU but not NEC.
 - BLU cable is listed but for only underground use, not for in buildings.

Question to the panel: An unlisted cable can be installed more than 50 feet into a building if it is in EMT conduit? True or False?

Unlisted Cables Entering a Building

- Article 725 only allows for Listed Cables.
- Article 770.48 Unlisted Cables and Raceways

(A) Conductive and Nonconductive Cables. Unlisted conductive and nonconductive outside plant optical fiber cables shall be permitted to be installed in building spaces, other than risers, ducts used for environmental air, plenums used for environmental air, and other spaces used for environmental air, where the length of the cable within the building, measured from its point of entrance, does not exceed 15 m (50 ft) and the cable enters the building from the outside and is terminated in an enclosure.

The point of entrance shall be permitted to be extended from the penetration of the external wall or floor slab by continuously enclosing the entrance optical fiber cables in rigid metal conduit (RMC) or intermediate metal conduit (IMC) to the point of emergence.

Unlisted Cables Entering a Building

- Article 770.48 Unlisted Cables and Raceways

(B) Nonconductive Cables in Raceway. Unlisted nonconductive outside plant optical fiber cables shall be permitted to enter the building from the outside and shall be permitted to be installed in any of the following raceways:

- (1) Intermediate metal conduit (IMC)
- (2) Rigid metal conduit (RMC)
- (3) Rigid polyvinyl chloride conduit (PVC)
- (4) Electrical metallic tubing (EMT)

Unlisted nonconductive outside plant cables installed in rigid polyvinyl chloride conduit (PVC) or electrical metallic tubing (EMT) shall not be permitted to be installed in risers, ducts used for environmental air, plenums used for environmental air, and other spaces used for environmental air.

Unlisted Cables Entering a Building

- **Article 800.48 Unlisted Cables Entering a Building.**

800.48 Unlisted Cables Entering Buildings. Unlisted outside plant communications cables shall be permitted to be installed in building spaces other than risers, ducts used for environmental air, plenums used for environmental air, and other spaces used for environmental air, where the length of the cable within the building, measured from its point of entrance, does not exceed 15 m (50 ft) and the cable enters the building from the outside and is terminated in an enclosure or on a listed primary protector. The point of entrance shall be permitted to be extended from the penetration of the external wall or floor slab by continuously enclosing the entrance cables in rigid metal conduit (RMC) or intermediate metal conduit (IMC) to the point of emergence.

Nowhere does it say you can add pull boxes or conduit bodies.

Unlisted Cables Entering a Building

- 800.2 Definitions

Point of Entrance. The point within a building at which the communications wire or cable emerges from an external wall, from a concrete floor slab, ~~from rigid metal conduit (RMC) or from intermediate metal conduit (IMC).~~

- 770.2 Definitions

Point of Entrance. The point within a building at which the optical fiber cable emerges from an external wall or from a concrete floor slab. ~~, from rigid metal conduit (RMC), or from intermediate metal conduit (IMC).~~

Question to the panel: An unlisted cable can be installed more than 50 feet into a building if it is in EMT conduit? False

Unlisted Cables Entering a Building

- 770.2 Definitions
- More than 50ft of non-listed cable can be installed in a building if routed in RMC or IMC for copper or fiber.
 - Providing the copper doesn't need a primary protector or the protector can be installed closer than 50ft.
 - Fiber optic cable can be installed in rigid PVC or EMT but these cannot be used to extend the point of entrance.

Unlisted Cables Entering a Building

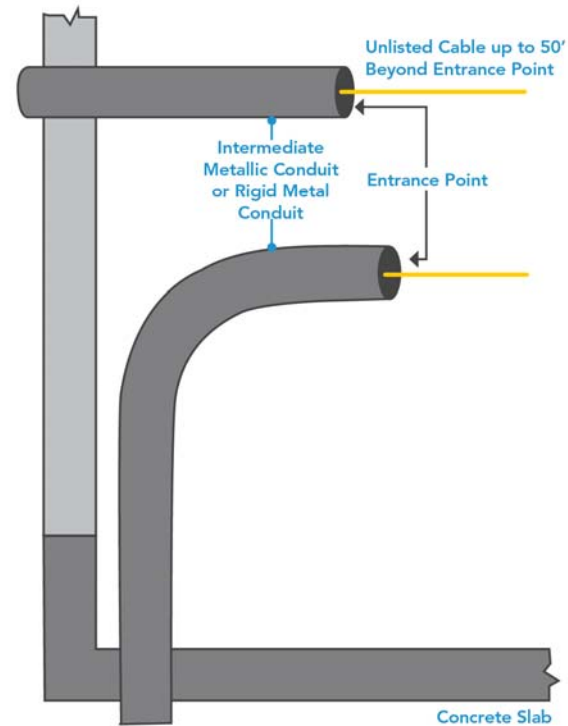
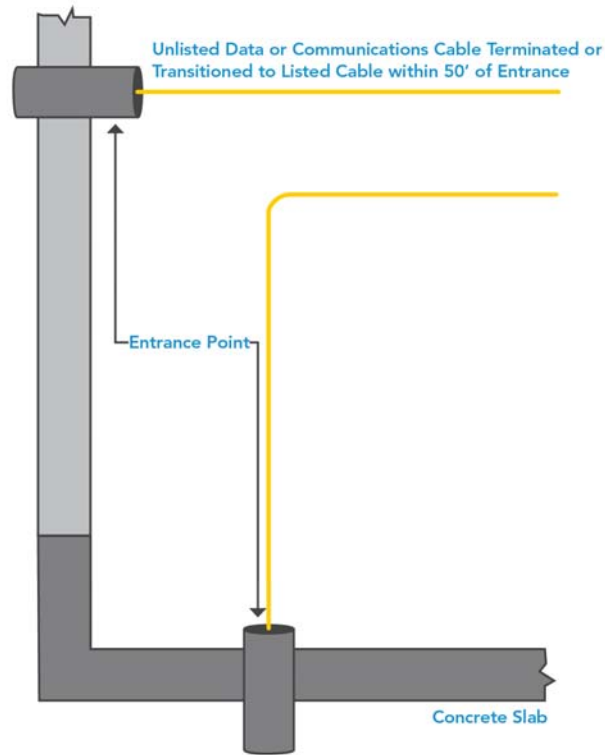

Circuit Protection

- Article 770 Part III: Does not require circuit protection. It does require non-current carrying conductors to be grounded or interrupted by an insulating joint or device.
- Article 725: Does not deal with circuit protection directly and instead refers you to Article 800 for circuits extending beyond one building, paragraph 725.141.

Circuit Protection

- Article 800 dedicates all of Part 3 to Protection
- 800.90 (A) Application.
 - Protectors are required on every circuit when:
 - the circuit is partly or entirely in aerial wire or cable not confined within a block
 - aerial or underground cable is located within a block exposed to power over 300 volts to ground
 - where there exists lightning exposure
- Informational Note No.1 advises for circuits not exposed to 300 volts to ground, providing listed protectors helps protect against other hazards such as lightning and above-normal voltage induced by fault currents.

Circuit Protection

- 800.90 (A) Information Note No.2 goes into more detail in the explanation of lightning exposure.

Informational Note No. 2: Interbuilding circuits are considered to have a lightning exposure unless one or more of the following conditions exist:

- in large metro areas where buildings are close together and high enough to intercept the lightning.
- Interbuilding cable runs 140 feet or less, with a metallic shield or in a continuous metal conduit where both ends are connected to the building grounding electrode.
- Areas having an average 5 or less thunderstorms per year and an earth resistivity of 100 ohm-meters. Such as on the Pacific Coast.

Circuit Protection

- Locate primary protector in, on or immediately adjacent to the structure being served and close as practical to the point of entrance.

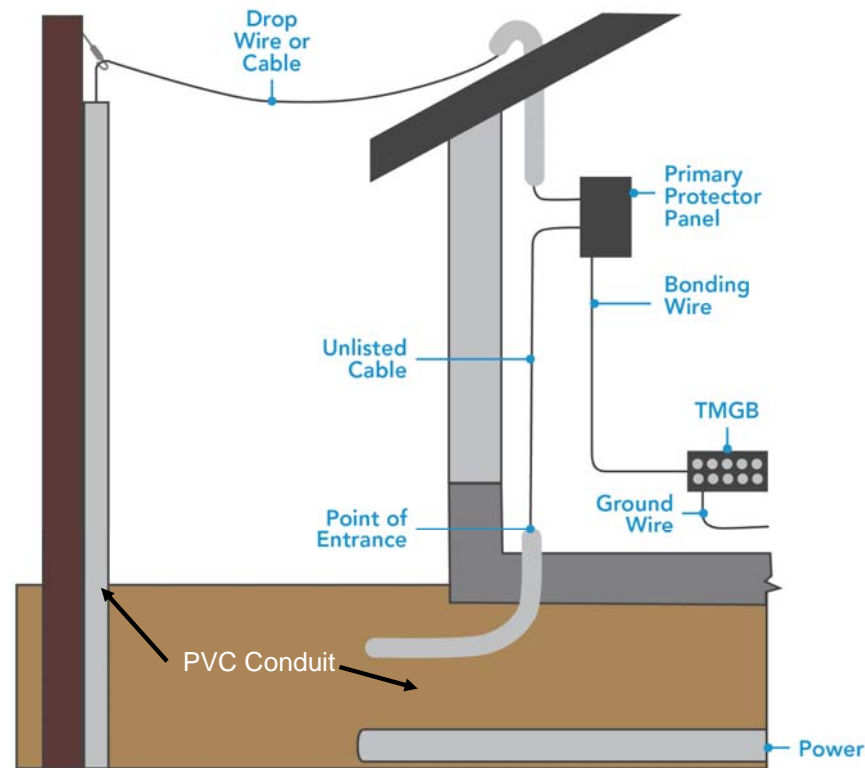

Circuit Protection

- Primary & Secondary Protectors.
 - The protector for the incoming service is the primary protector.
 - The use of a secondary protector between the primary protector and the indoor cabling or equipment is allowed by the Code.
 - The secondary protector has to be Listed for its purpose.
 - A secondary protector cannot be in lieu of a primary protector.
 - These are often seen on the incoming lines into a KSU telephone switch or telecom equipment to provide an extra level of protection.

Circuit Protection

- Fuseless and fused protectors
 - Fuseless are the most common protectors sold for telephony.
 - Solid State and Gas Tube protectors are designed to automatically reset after the surge has passed.
 - 800.90 (A) (1) list several permitted conditions which fuseless protectors can be used.
 - If conditions cannot be met, a fuse type protector must be used.
 - Fused protectors are good for one surge and then they create an open circuit and must be replaced.

The End

Tim Kuhlman
tim.kuhlman@teecom.com

